

BMP No. 1

Access Roads, Skid Trails, and Landings

The purpose of this BMP is to minimize soil erosion and protect nearby water bodies from sediments from the construction, use, maintenance, and retirement of roads, skid trails, and landings.

Equipment Operations and Excessive Rutting

Minimum Requirement:

Do not operate skidders or other logging equipment off hard surfaced roads under conditions that will cause excessive rutting.

Excessive rutting is defined as a point where ruts cannot be resurfaced with available equipment.

Road Grades

Minimum Requirement:

Grades should be kept to a minimum. When possible, access roads should not exceed a grade of 15 percent except for short stretches of 200 feet or less where grades should not exceed 18 percent.

Controlling Erosion and Runoff from Roads

Minimum Requirement:

Install water bars, culverts, or other drainage structures at appropriate intervals.

Crowning and Turnouts

- **Crowning** consists of raising the center of the road to **allow water to run off the road** on either side. In some cases, ditches along the road catch the water. Crowning is best used for roads that have little slope.
- **Turnouts** are a continuation of the road ditch angled away from the road (normally at a 30 degree angle) that allows water to run off into the undisturbed forest. Turnout spacing should be consistent with Table 1-1.

Out-sloping

Out-sloping is a drainage technique where the entire width of the road is gently sloped toward the outside or fill-bank side of the road.

- **A recommended side slope for this type of road is one-fourth inch per foot or a 3-inch drop per 12 feet of road width.** Out-sloped roads can be hazardous when slick from moisture, ice, or snow.

In-sloping and Cross Drains

In-sloping is a drainage technique where the entire width of the road is gently sloped toward the inside or uphill side of the road. Surface runoff is diverted into a ditch against the inside cut bank of the road. Cross drain structures are designed to be used with roads that are wholly or partially in-sloped. These are structures that are used to move the water from the in-slope ditch across the road to the undisturbed forest floor.

- **In-sloping: Recommended in-slope is one-fourth inch per foot or a 3-inch drop per 12 feet of road width.**
- **Cross Drain Structures** include reverse grade structures and open and closed culverts.

Table 1-1—Appropriate Distances for Cross Drain Structures

Road Grade (%)	Spacing (slope distance in feet)
2-5	300-500
6-10	200-300
11-15	100-200
16-18	100

Note: Deviations from these recommendations may be appropriate depending on the nature of the road surface material and its tendency to erode.

Reverse Grade Structures

Reverse grade structures are constructed using a hump and dip across the road to stop the downhill movement of water and move the water off the road into the undisturbed forest. Figure 1-1 shows a basic design for a reverse grade structure. The hump is pushed up above the surface of the road from material out of the dip which is dug below the normal road surface. Recommended specifications for different applications on roads are presented in Figures 1-1 and 1-2

Figure 1-1—Typical Reverse Grade Structure

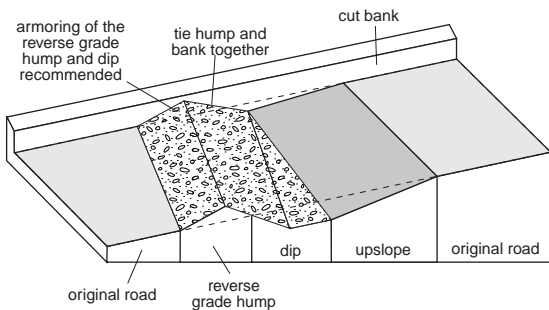

Reverse Grade Structures for Gentle Grades

Use: For roads where heavy equipment is used on moderate grades (less than 10 percent).

Specifications: Figure 1-2 provides general specifications. Armoring, with crushed rock, can help maintain the structure.

Spacing: Table 1-1.

Maintenance: Frequent inspection and repair of humps and dips which may need restructuring. Check for erosion at the outlet. If needed, use rocks, logs, or cutoffs to slow water at outlet.

Figure 1-2—Reverse Grade Structures for Gentle Grades

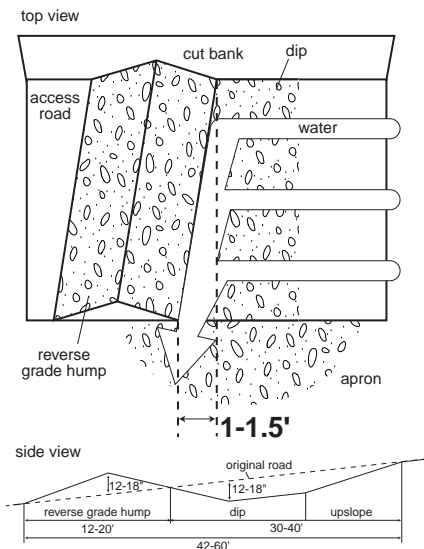

Note: These drawings are not drawn to scale.

Reverse Grade Structures for Steep Roads

Use: For roads with grades 10 to 18 percent.

Specifications: Figure 1-3 provides general dimension recommendations. Armoring can help maintain structure.

Spacing: Table 1-1.

Maintenance: Frequent inspection and repair of humps and dips which may need restructuring. Check for erosion at the outlet. If needed, use rocks, logs, or cutoffs to slow water at outlet.

Figure 1-3—Reverse Grade Structure for Steep Slopes

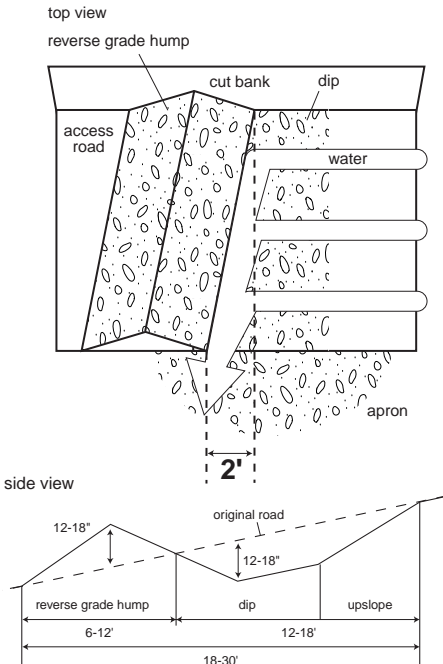

Note: These drawings are not drawn to scale.

Closed Culverts

Use: For use on in-sloped roads, especially where frequently running springs and seeps are found.

Type of Pipes: Single-walled corrugated plastic, double-walled smooth plastic, or corrugated metal.

Specifications: Figure 1-4 shows top and side specifications. Figure 1-5 shows specifications for burying pipe.

Figure 1-4—Top and Side View of Closed Culvert

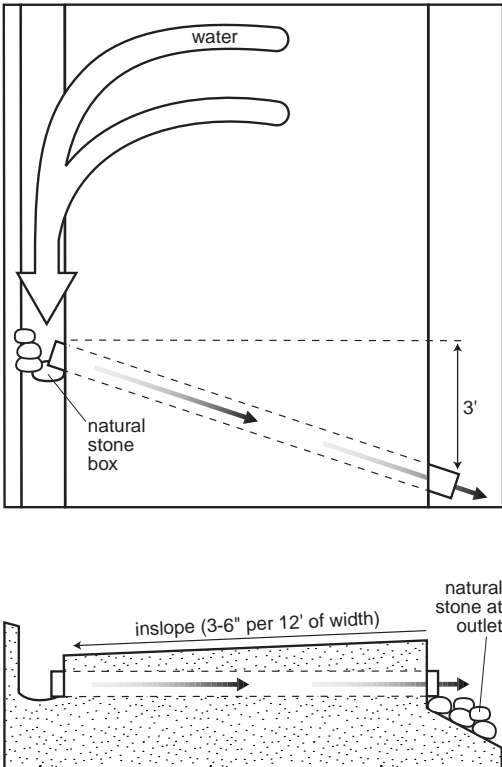

Pipe Diameter: Minimum of 12 inches (corrugated metal) or equivalent size double-walled plastic.

Spacing: Table 1-1.

Maintenance: Removal of materials from the inlet of closed culverts is often necessary. Check mid-sections for blockage and outlets for the development of erosion. Rocks or other materials can be used to dissipate water flowing from culverts.

Figure 1-5–Cross-Sectional View of Closed Culvert

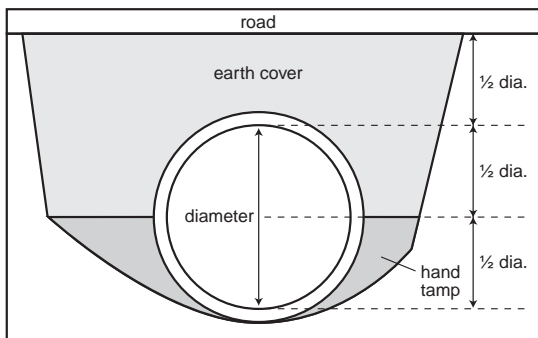

Open-topped Culverts

Use: Draining surface waters and frequently running springs and seeps on **well-compacted or settled roads**. This type of culvert can fill quickly when used on newly disturbed access roads.

Specifications: Pole culverts (Figure 1-5) and box culverts (Figure 1-6).

Spacing: Table 1-1 or at seeps and springs, as appropriate.

Maintenance: Box culverts can also be damaged by dozer cleats. All open-topped culverts must be cleaned frequently.

Figure 1-6–Open-topped Pole Culvert

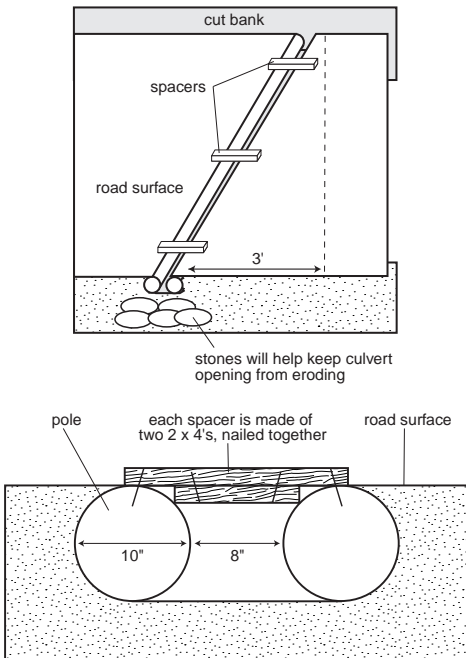
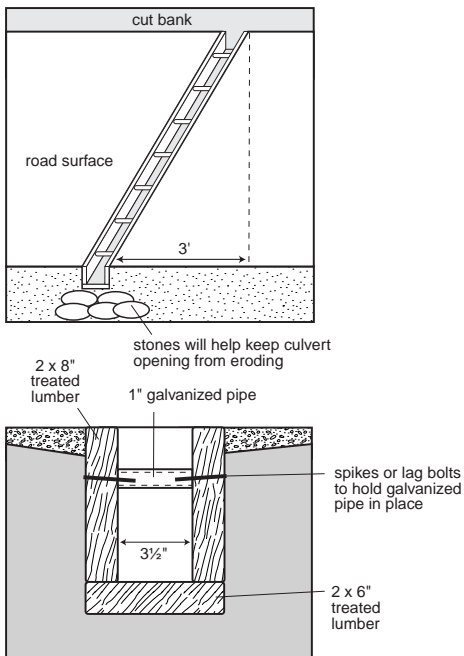

Figure 1-7–Open-topped Box Culvert



Stream and Channel Crossings

Proper crossing of streams and channels is important for avoiding water quality problems. Streams and drainage channels include:

- **Perennial streams:** Flowing water throughout the year.
- **Intermittent streams:** Streams having defined banks, flowing only during the wet portions of the year and in response to rain events.
- **Ephemeral channels:** Channels containing water only during or directly after rain events.

Minimum Requirement:

Use or install bridges or culverts to cross streams (perennial or intermittent) or ephemeral channels, where feasible. Cross streams or ephemeral channels at right angles.

Note: Stream crossings, particularly those where streams drain more than one square mile, may be subject to regulations. See Streams and Other Waters BMP No. 1 and Appendix A (Construction in Floodplains) for further information. Further information may also be obtained by contacting the Kentucky Division of Water (502-564-3410) or a field office of the Kentucky Division of Forestry (see Appendix F). Ephemeral channel crossings do not require permits.

Bridges

Use: For crossing perennial and intermittent streams as well as ephemeral channels.

Specifications: Bridges can be made from a variety of materials. Some commercially built portable bridges are available. Figure 1-8 provides specifications which have been used successfully on the Daniel Boone National Forest. The integrity and the safety of the bridge approach are critical as well as the ability to maintain traction when the surface is wet or frozen.

Maintenance: Check approaches and structure for wear. Armor or rip-rap loose fill along stream banks where appropriate.

Figure 1-8—Diagram of a Log Stringer Bridge

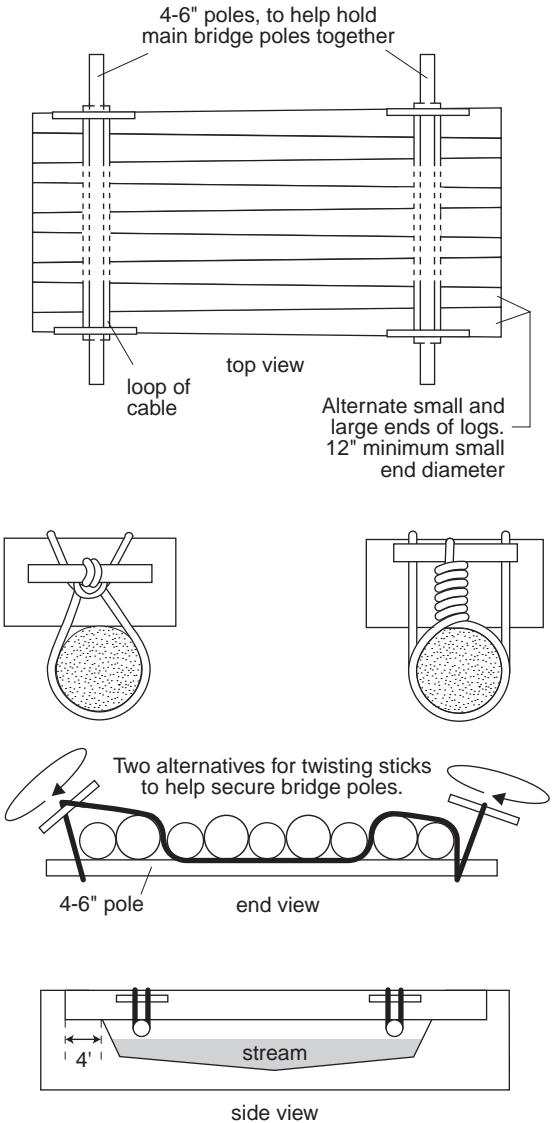

Culverts

Use: For crossing ephemeral channels and some intermittent and perennial streams.

Specifications: Culvert inlets should be placed level with the drainage and as near as possible to the natural channel. In some instances, where the culvert level has to be lower than the drainage gradient, a drop box can be constructed. Figure 1-9 shows components for an ephemeral channel crossing. Adequate cover over the culvert is needed, the rule being a minimum of one foot or half the culvert diameter, whichever is greater. If adequate cover cannot be achieved, then an arch pipe, “squashed pipe,” or two smaller culverts should be installed. Table 1-2 provides information on culvert sizing.

Maintenance: Check for erosion of bank near inlet and erosion of fill. Inspect for obstructions or objects directly up the channel that could be washed into the culvert. Rip-rap or armor fill surrounding the culvert opening as needed.

Figure 1-9—Culvert Used for Crossing Channel

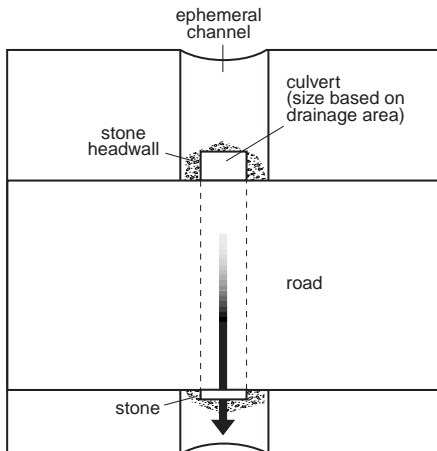

Table 1-2—Recommended Pipe Diameters for Streams and Ephemeral Channels

Area above Pipe (acres)	Recommended Pipe Diameter (inches)
2	12
4	15
7	18
12	21
16	24
27	30
47	36
64	42
90	48
120	54
160	60
205	66
250	72
350	78

Hollow Logs

Use: Hollow logs can be used only for temporary crossing of ephemeral channels or small streams since they have a shorter life span than man-made culverts.

Specifications:

- **The butt or large end** of the log should be placed **downstream**, to avoid premature obstruction within the log.
- **Use several logs**, if possible, to increase the capacity and allow flow if one becomes obstructed.
- **Provide adequate soil coverage** to avoid collapse under normal traffic conditions.
- **Oversize** logs relative to man-made culverts.

Maintenance: Same as culverts. Hollow log crossings should be removed after use.

Fords

Use: General use for stream crossings where bottom material is firm.

Specifications: For permanent-use roads, fords should be graveled on each side where significant soil disturbance may occur. The road should have a reverse grade structure or other water diversion to prevent water from running down the road into the stream during high flows. Fill areas and disturbed banks in the vicinity of stream crossings should be stabilized promptly.

Maintenance: Maintain proper stabilization of banks. Ensure that up-slope road drainage structures are adequately maintained to avoid surface drainage into stream.

Low Water Crossings

Use: General stream crossings.

Specifications: The Division of Water (502-564-3410) has developed a standard design that is typically acceptable for issuance of a floodplain permit. This design is available on request. See Streams and Other Waters BMP No. 1 and Appendix A.

Maintenance: Maintain proper stability of banks. Ensure that up-slope road drainage structures are adequately maintained to avoid surface drainage into stream. Regularly inspect structural aspects of crossings, especially after high water.

Minimum Requirement:

<p>Do not operate skidders or other logging equipment off hard-surfaced roads under conditions that may cause the development of excessive rutting.</p>

Excessive rutting is defined as a point where ruts cannot be resurfaced with available equipment.

Landing or Log Deck Location

Minimum Requirement:

Locate yards and landings outside of SMZs. Yards and landings should have adequate drainage.

Note: See BMP No. 3 Streamside Management Zones for further information.

Soil and Logging Slash

Minimum Requirements:

- Disturbed soil or concentrated logging slash should not be left in ephemeral channels.
- Tops or other logging debris which may block stream channels should be removed or placed in such a way that they will not cause a blockage.

Note: See BMP No. 5 for further information on disturbed soil, logging slash, and trash.

Controlling Erosion and Runoff from Active Skid Trails

The following guidelines will aid in proper skid trail construction.

- **Grades:** Keep skid trail grades as low as topography will permit. Do not go straight up the slope but proceed on a slant or zig-zag path and avoid long, steep slopes.
- **Ephemeral channels:** Where possible, use culverts, temporary bridges, or other structures at ephemeral channels.

- **Stream crossings:** Minimize the number of stream crossings. Where crossings are needed, properly install bridges, culverts, or use fords or low water crossings at right angles.
- **Drainage:** All trails should have drainage using turnouts and natural dips. Allowing water to accumulate on trail surfaces may lead to unwanted flows into streams or channels.
- **Bank seeps** need drainage control structures (which can be skidded across) immediately below them.
- **Extra steep skid trails** need drainage control structures (which can be skidded across) immediately above them.
- **Skidding over wet soils** may cause excessive rutting and should be avoided, if possible. Excessive rutting can be practically defined as a depth exceeding the ability of the available equipment to resurface the trail.
- **Maintenance** includes preventing water from accumulating on trails. **Berms** of dirt pushed up along the edge of trails often prevents water from draining and should be periodically removed. **Temporarily unused trails** need to have drainage control structures constructed to prevent rill and gully erosion.

Minimum Requirements:

- | |
|--|
| <ul style="list-style-type: none"> • Do not operate skidders or other logging equipment off hard-surfaced roads under conditions that may cause the development of excessive rutting. Excessive rutting is defined as a point where ruts cannot be eliminated with available equipment. • Disturbed soil or concentrated logging slash should not be left in ephemeral channels. • Install water bars, culverts, or other drainage structures at appropriate intervals. |
|--|

Skidding in Streams

Minimum Requirement:

Stream beds should not be used as roads or for the skidding of logs except where the geology or other physical conditions of the site (rock walls, notches, or other limiting factors) leave no other alternatives for access, or where skid trail placement in normally recommended locations is either impossible or will cause a higher degree of water quality degradation. If an exception due to physical site conditions is necessary, stream channels may be used as roads or for skidding only for the minimum distance required.

Retirement

Access Roads and Landings

Access roads or landings should be retired if further use is not planned.

- **Smooth and reshape** surfaces and banks, and remove ruts and berms.
- **Revegetate** disturbed areas as soon as is practical. See BMP No. 2 for recommended seeding mixes and treatments.
- **Control vehicle access** on retired roads until cover is established and the road has settled.
- **Open-topped culverts** should be removed and replaced with closed culverts or reverse-grade structures. These structures should be of sufficient size to carry maximum runoff to prevent them from being washed out. See “Pipe Culvert” specification.
- **Out-sloping** or returning to original contour can also be used for the retirement of access roads.
- **Disturbed soil should not be left in ephemeral channels.**
- **Logging debris and fill** should not be pushed over stream banks or left so that they will enter streams or other waters (see BMP No. 5).

Skid Trails

On completion of the skidding operation **or a seasonal shut-down**, trails should be retired.

- **Water bars:** A reverse grade drainage control structure designed specifically for skid trails can be used (**Figure 1-10**). A skidder bar, shown in **Figure 1-11**, is an alternative to water bars and can be constructed with wheeled skidders. **Table 1-3** provides recommended spacing for water and skidder bars.
- **Out-sloping:** Skid trails can be out-sloped or returned to original contour to minimize or permanently eliminate or reduce erosion.

- **Stream crossings:** At stream crossings, the stream beds should be cleaned of debris and restored to natural shape and grade.
- **Revegetation:** Skid trail sections having bare soil (primary skid trails) should be revegetated in a similar manner to access roads. See BMP No. 2 for details.
- **Ephemeral channels:** Remove disturbed soil or concentrated logging slash from ephemeral channels.
- **Access** must be controlled or restricted on retired trails to allow settling and revegetation.

Table 1-3—Recommended Distances¹ between Water Bars for Retirement of Skid Trails

Skid Trail Percent	Spacing (slope distance in feet)
1	400
2	245
5	125
10	78
15	58
20	47
25	40
30	35
35	32
40	29

1 Actual distance between water bars will depend upon the nature of the road surface material, its tendency to erode, and hydrologically active areas, such as seeps.

Figure 1-10–Water Bars (or Deep Water Breaks) for Skid Trail Retirement

top view

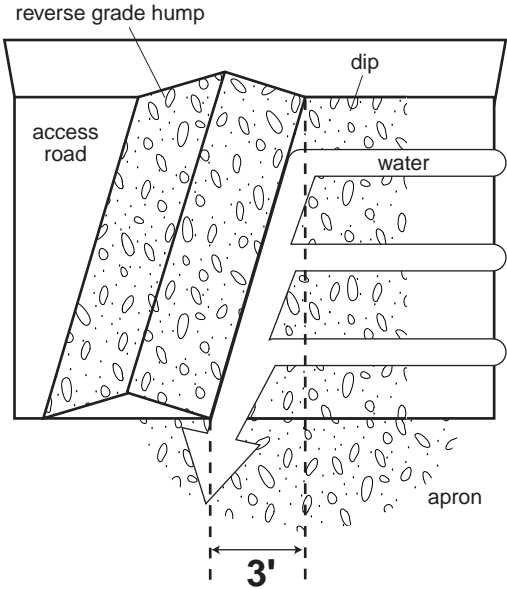

side view

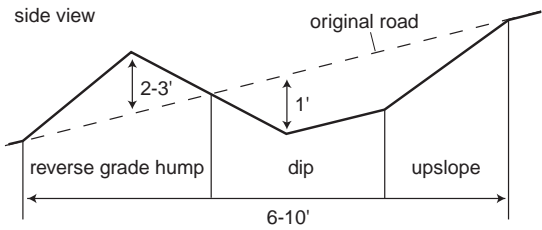

Note: These drawings are not drawn to scale.

The **skidder bar** has been designed as an alternative structure. Figure 1-11 shows the sequence of pushes used to create the skidder bar as well as the design specifications.

This structure is developed from a series of 1- to 2-foot tall piles. These piles are developed by the skidder scraping surface soil. Do not attempt to dig the dip below the hard packed surface of the trail. Overlapping the piles is critical to prevent leakage. The final push clears the berm to allow drainage.

Figure 1-11-Skidder Bars

