

FOR-69

# Field Guide to Best Management Practices for Timber Harvesting in Kentucky



*Cooperative Extension Service*  
University of Kentucky • College of Agriculture  
Agriculture • Home Economics • 4-H • Development

# **Field Guide to Best Management Practices for Timber Harvesting in Kentucky**

Jeffrey W. Stringer, Ph.D.  
Department of Forestry  
University of Kentucky  
Lexington, KY 40546-0073

Larry Lowe  
Kentucky Division of Forestry  
627 Comanche Trail  
Frankfort, KY 40601

Mathew Smidt, Ph.D.  
Department of Forestry  
Robinson Substation  
125 Robinson Road  
Quicksand, KY 41339-9007

Cary Perkins  
Kentucky Division of Forestry  
627 Comanche Trail  
Frankfort, KY 40601

## *Acknowledgments*

This document was printed with specially designated funds from an *Act Relating to Agricultural Chemical Usage* passed by the 1990 Kentucky General Assembly.



# Table of Contents

---

What Is in This Guide .....	4
Quick Reference for Determining Timber Harvesting BMPs .....	5
Planning for Proper BMP Effectiveness .....	7
Common Measurements Needed for BMP Implementation .....	9
<b>BMP No. 1:</b> Access Roads, Skid Trails, and Landings .....	10
<b>BMP No. 2:</b> Vegetative Establishment of Silviculturally Disturbed Areas .....	32
<b>BMP No. 3:</b> Streamside Management Zones .....	39
<b>BMP No. 4:</b> Sinkholes .....	47
<b>BMP No. 5:</b> Logging Debris .....	50
<b>BMP No. 7:</b> Fertilizers .....	52
<b>BMP No. 10:</b> Timber Harvesting in Wetland Areas ...	53
Streams and Other Waters BMPs .....	56
Appendix A: Regulatory Requirements All Silvicultural Operations, 401 KAR 5:026, 5:029, 5:030, and 5:031 .....	58
Appendix B: Kentucky Bodies of Water Designated as Coldwater Aquatic Habitats .....	61
Appendix C: Locations of Kentucky Wild Rivers .....	65
Appendix D: High-Quality Waters .....	66
Appendix E: Surface Waters Categorized as Outstanding National Resource Waters .....	69
Appendix F: Technical Assistance Providers: State Offices .....	70

# What Is in This Guide

---

This guide was designed as a field reference for timber harvesting operations. It contains minimum requirements and specifications of Best Management Practices (BMPs) appropriate for timber harvesting operations in Kentucky. Use of these BMPs will help reduce or eliminate sources of water pollution from:

- movement of sediments to streams and other waters;
- changes in stream temperatures;
- alteration of stream flow due to sediment deposits, tree tops, and other debris;
- movement of substances harmful to waters, such as vehicle fluids and fertilizers.

This guide includes the minimum requirements mandated by the Agriculture Water Quality State Plan. These minimum requirements are found in the highlighted boxes in each BMP. This guide also includes recommendations for meeting these minimum requirements as found in BMPs 1, 2, 3, 4, 5, 7, and 10 of the 1997 edition of the *Kentucky Forest Practice Guidelines for Water Quality Management (1997)*. BMPs 6, 8, 9, 11, 12, and 13 are not included in this guide as they involve reforestation and fire control issues.

# Quick Reference for Determining Timber Harvesting BMPs

---

The following reference can be used to determine the appropriate BMPs for protecting water quality. The BMPs determined using this reference satisfy the Silviculture (including timber harvesting) and the Streams and Other Waters sections of the Kentucky Agriculture State Water Quality Plan. Use one or more of the following BMPs if your answer is “yes”:

**Questions 1 through 6** are for Silvicultural BMPs for Timber Harvesting.

1. As part of any timber harvesting operation, will roads, skid trails, and/or log landings be constructed, used, and/or maintained?

Yes       No

*If yes, use Silvicultural BMP No. 1 (pg. 10) and BMP No. 5 (pg. 50).*

2. Does the area where the timber harvesting operation is to occur contain—or is it directly adjacent to—perennial or intermittent streams or other bodies of water?

Yes       No

*If yes, use Silvicultural BMP No. 3 (pg. 39) and BMP No. 5 (pg. 50), also see questions 7-10.*

3. Does the boundary or tract where the timber harvesting operation is to occur contain sink-holes?

Yes       No

*If yes, use Silvicultural BMP No. 4 (pg. 47) and BMP No. 5 (pg. 50).*

4. In conjunction with the timber harvesting operation, are there disturbed or otherwise bare areas (such as roads, skid trails, or landings)

that need to be revegetated to prevent and/or control soil erosion?

Yes       No

*If yes, use Silvicultural BMP No. 2 (pg. 32).*

- 5.** Will timber harvesting activities occur in areas classified as wetlands by the Natural Resources Conservation Service (NRCS) or the U.S. Army Corps of Engineers?

Yes       No

*If yes, use Silvicultural BMP No. 10 (pg. 53).*

- 6.** Will fertilizers be used in connection with your timber harvesting activities?

Yes       No

*If yes, use Silvicultural BMP No. 7 (pg. 52).*

**Questions 7 through 10** are for Streams and Other Waters BMPs (as found in the Kentucky Agriculture Water Quality Authority Producer Workbook.

- 7.** Do you have to cross a stream with vehicles as part of your operation?

Yes       No

*If yes, use Streams and Other Waters BMP No. 1.*

- 8.** Are there sand or gravel deposits in any stream that you will remove?

Yes       No

*If yes, use Streams and Other Waters BMP No. 2.*

- 9.** Are any stream banks scouring, caving in, or sloughing off?

Yes       No

*If yes, use Streams and Other Waters BMP No. 3.*

- 10.** Do any streams have logjams or sediment blockages that need removing?

Yes       No

*If yes, use Streams and Other Waters BMP No. 4.*

# Planning for Proper BMP Effectiveness

---

The following provides a guide for planning road, trail, and landing placement which is critical to effective BMP use and water quality protection.

## **Determining Control Points**

**Control points** affect the placement of the roads, trails, and landings. Control points are features of the landscape such as:

- highway access points,
- wood roads,
- water courses (streams, sloughs, springs, and ponds),
- seeps,
- rock outcrops,
- thin soils, and
- sinkholes.

## **Using Maps and a Walk-Through**

Use topographic maps and a thorough walk-through to determine the location of **control points**. Figure 1 shows a timber harvest boundary sketched on a topographic map. Topographic maps contains curved lines, called contour lines, which represent a particular elevation. Several of the control points, such as streams, sinkholes, ephemeral channels, and the location of roads, were identified from the topographic map prior to the walk-through. During the walk-through, several other control points were also identified, including areas with thin soils and rock outcrops and a potential site for the landing.

## Planning the Location of the Roads and Landings

Use the established control points and road standards to establish the preliminary access road location following these general recommendations:

- Minimize the number of stream crossings.
- Maintain minimum SMZ distances to streams (see BMP No. 3).
- Avoid sinkholes, if possible (see BMP No. 4).
- Avoid drainages such as ephemeral channels, if possible.
- Maintain appropriate road grade (see BMP No. 1).

**Figure 1—Topographic Map with Control Points**

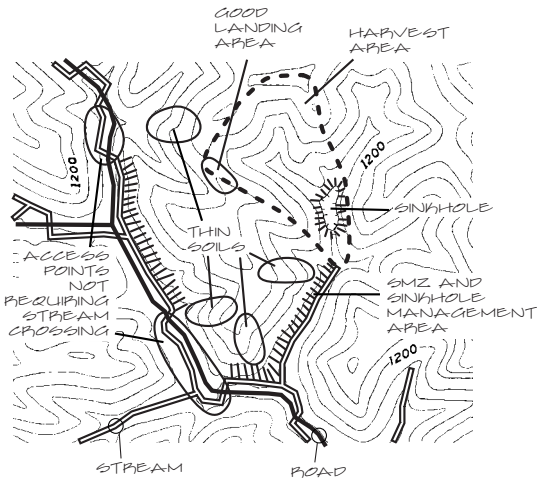

# Common Measurements Needed for BMP Implementation

---

## Slope Measurement

Slope is measured as the rise or fall over a 100-foot horizontal distance. Slope percent describes the steepness of a hill or road and is used for implementing BMPs like water bars or Streamside Management Zones.

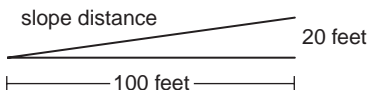

In this example  $20 \text{ feet} \div 100 \text{ feet} = 0.20$

or a 20 percent slope.

A scale for estimating slope percent is provided on the back of this *Guide*.

## Slope Distance

Distances used in this *Guide* refer to slope distances or the linear distance along the ground, not the horizontal distance.

# **BMP No. 1**

## **Access Roads, Skid Trails, and Landings**

---

The purpose of this BMP is to minimize soil erosion and protect nearby water bodies from sediments from the construction, use, maintenance, and retirement of roads, skid trails, and landings.

### **Equipment Operations and Excessive Rutting**

*Minimum Requirement:*

Do not operate skidders or other logging equipment off hard surfaced roads under conditions that will cause excessive rutting.

Excessive rutting is defined as a point where ruts cannot be resurfaced with available equipment.

### **Road Grades**

*Minimum Requirement:*

Grades should be kept to a minimum. When possible, access roads should not exceed a grade of 15 percent except for short stretches of 200 feet or less where grades should not exceed 18 percent.

### **Controlling Erosion and Runoff from Roads**

*Minimum Requirement:*

Install water bars, culverts, or other drainage structures at appropriate intervals.

## **Crowning and Turnouts**

- **Crowning** consists of raising the center of the road to **allow water to run off the road** on either side. In some cases, ditches along the road catch the water. Crowning is best used for roads that have little slope.
- **Turnouts** are a continuation of the road ditch angled away from the road (normally at a 30 degree angle) that allows water to run off into the undisturbed forest. Turnout spacing should be consistent with Table 1-1.

## **Out-sloping**

Out-sloping is a drainage technique where the entire width of the road is gently sloped toward the outside or fill-bank side of the road.

- **A recommended side slope for this type of road is one-fourth inch per foot or a 3-inch drop per 12 feet of road width.** Out-sloped roads can be hazardous when slick from moisture, ice, or snow.

## **In-sloping and Cross Drains**

In-sloping is a drainage technique where the entire width of the road is gently sloped toward the inside or uphill side of the road. Surface runoff is diverted into a ditch against the inside cut bank of the road. Cross drain structures are designed to be used with roads that are wholly or partially in-sloped. These are structures that are used to move the water from the in-slope ditch across the road to the undisturbed forest floor.

- **In-sloping: Recommended in-slope is one-fourth inch per foot or a 3-inch drop per 12 feet of road width.**
- **Cross Drain Structures** include reverse grade structures and open and closed culverts.

**Table 1-1—Appropriate Distances for Cross Drain Structures**

Road Grade (%)	Spacing (slope distance in feet)
2-5	300-500
6-10	200-300
11-15	100-200
16-18	100

Note: Deviations from these recommendations may be appropriate depending on the nature of the road surface material and its tendency to erode.

### Reverse Grade Structures

Reverse grade structures are constructed using a hump and dip across the road to stop the downhill movement of water and move the water off the road into the undisturbed forest. Figure 1-1 shows a basic design for a reverse grade structure. The hump is pushed up above the surface of the road from material out of the dip which is dug below the normal road surface. Recommended specifications for different applications on roads are presented in Figures 1-1 and 1-2

**Figure 1-1—Typical Reverse Grade Structure**

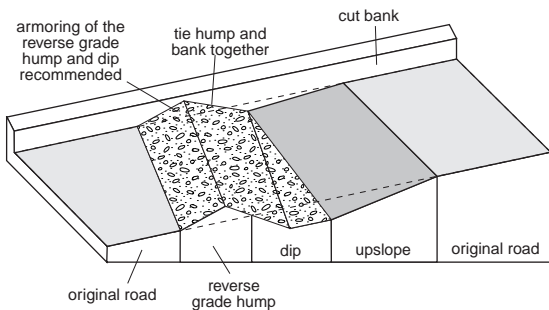

## Reverse Grade Structures for Gentle Grades

**Use:** For roads where heavy equipment is used on moderate grades (less than 10 percent).

**Specifications:** Figure 1-2 provides general specifications. Armoring, with crushed rock, can help maintain the structure.

**Spacing:** Table 1-1.

**Maintenance:** Frequent inspection and repair of humps and dips which may need restructuring. Check for erosion at the outlet. If needed, use rocks, logs, or cutoffs to slow water at outlet.

**Figure 1-2—Reverse Grade Structures for Gentle Grades**

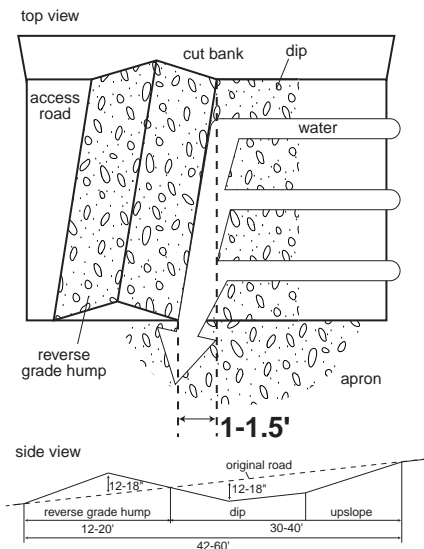

Note: These drawings are not drawn to scale.

## Reverse Grade Structures for Steep Roads

**Use:** For roads with grades 10 to 18 percent.

**Specifications:** Figure 1-3 provides general dimension recommendations. Armoring can help maintain structure.

**Spacing:** Table 1-1.

**Maintenance:** Frequent inspection and repair of humps and dips which may need restructuring. Check for erosion at the outlet. If needed, use rocks, logs, or cutoffs to slow water at outlet.

**Figure 1-3—Reverse Grade Structure for Steep Slopes**

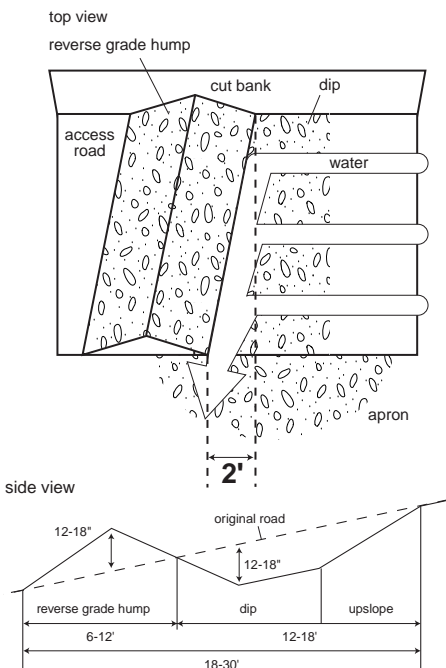

Note: These drawings are not drawn to scale.

## Closed Culverts

**Use:** For use on in-sloped roads, especially where frequently running springs and seeps are found.

**Type of Pipes:** Single-walled corrugated plastic, double-walled smooth plastic, or corrugated metal.

**Specifications:** Figure 1-4 shows top and side specifications. Figure 1-5 shows specifications for burying pipe.

**Figure 1-4—Top and Side View of Closed Culvert**

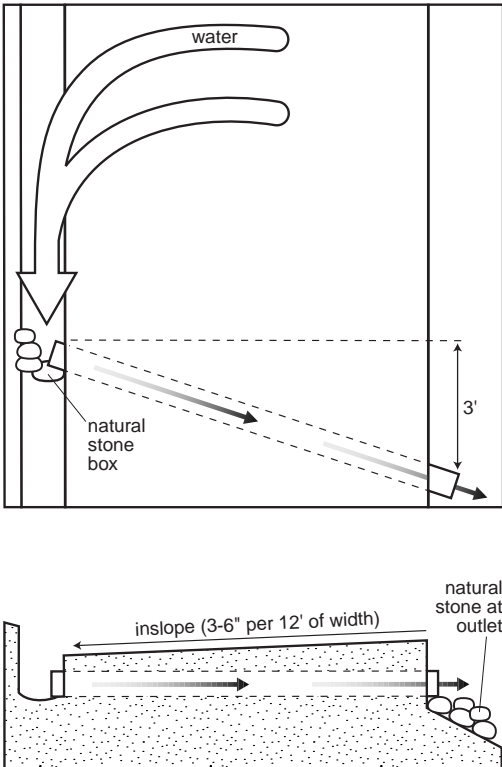

**Pipe Diameter:** Minimum of 12 inches (corrugated metal) or equivalent size double-walled plastic.

**Spacing:** Table 1-1.

**Maintenance:** Removal of materials from the inlet of closed culverts is often necessary. Check mid-sections for blockage and outlets for the development of erosion. Rocks or other materials can be used to dissipate water flowing from culverts.

**Figure 1-5–Cross-Sectional View of Closed Culvert**

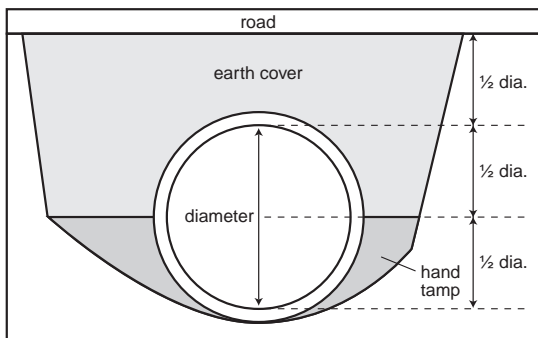

## Open-topped Culverts

**Use:** Draining surface waters and frequently running springs and seeps on **well-compacted or settled roads**. This type of culvert can fill quickly when used on newly disturbed access roads.

**Specifications:** Pole culverts (Figure 1-5) and box culverts (Figure 1-6).

**Spacing:** Table 1-1 or at seeps and springs, as appropriate.

**Maintenance:** Box culverts can also be damaged by dozer cleats. All open-topped culverts must be cleaned frequently.

**Figure 1-6—Open-topped Pole Culvert**

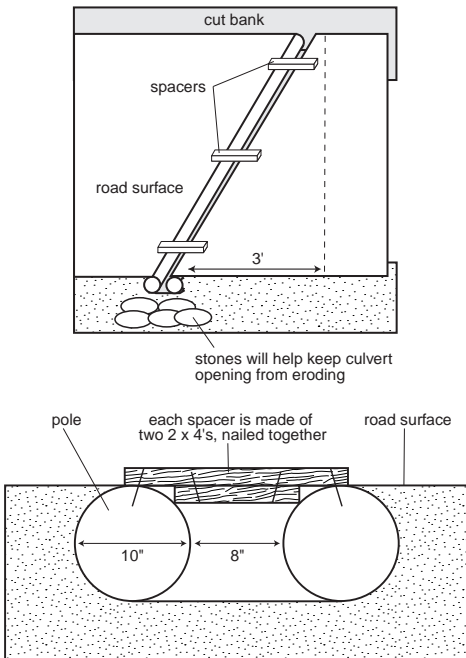

**Figure 1-7–Open-topped Box Culvert**

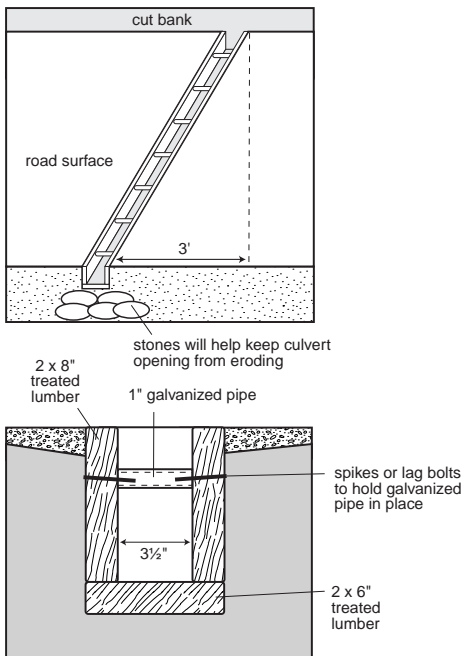

## **Stream and Channel Crossings**

Proper crossing of streams and channels is important for avoiding water quality problems. Streams and drainage channels include:

- **Perennial streams:** Flowing water throughout the year.
- **Intermittent streams:** Streams having defined banks, flowing only during the wet portions of the year and in response to rain events.
- **Ephemeral channels:** Channels containing water only during or directly after rain events.

### *Minimum Requirement:*

Use or install bridges or culverts to cross streams (perennial or intermittent) or ephemeral channels, where feasible. Cross streams or ephemeral channels at right angles.

**Note:** Stream crossings, particularly those where streams drain more than one square mile, may be subject to regulations. See Streams and Other Waters BMP No. 1 and Appendix A (Construction in Floodplains) for further information. Further information may also be obtained by contacting the Kentucky Division of Water (502-564-3410) or a field office of the Kentucky Division of Forestry (see Appendix F). Ephemeral channel crossings do not require permits.

### **Bridges**

**Use:** For crossing perennial and intermittent streams as well as ephemeral channels.

**Specifications:** Bridges can be made from a variety of materials. Some commercially built portable bridges are available. Figure 1-8 provides specifications which have been used successfully on the Daniel Boone National Forest. The integrity and the safety of the bridge approach are critical as well as the ability to maintain traction when the surface is wet or frozen.

**Maintenance:** Check approaches and structure for wear. Armor or rip-rap loose fill along stream banks where appropriate.

**Figure 1-8—Diagram of a Log Stringer Bridge**

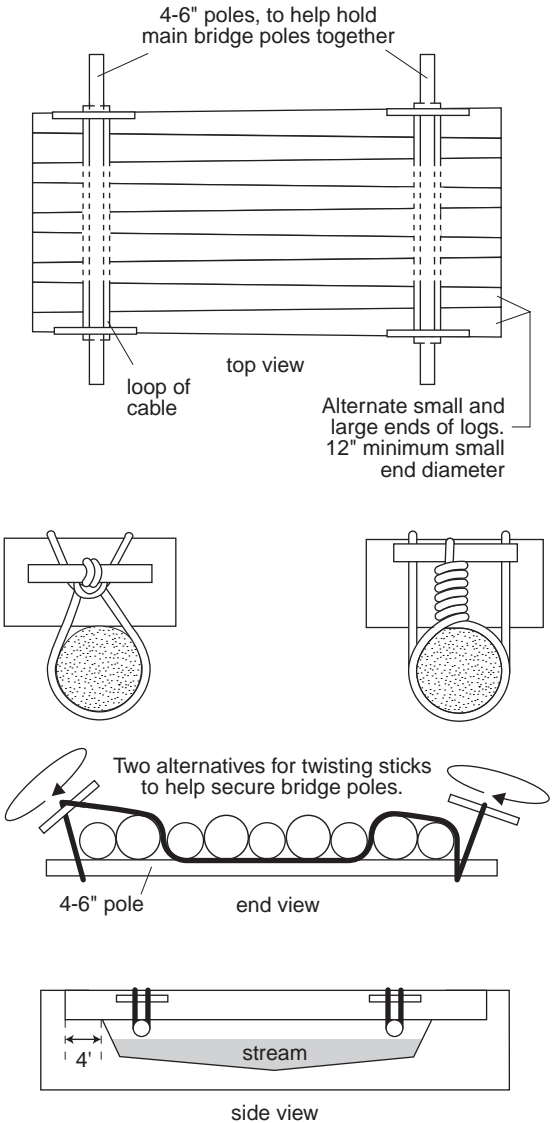

## Culverts

**Use:** For crossing ephemeral channels and some intermittent and perennial streams.

**Specifications:** Culvert inlets should be placed level with the drainage and as near as possible to the natural channel. In some instances, where the culvert level has to be lower than the drainage gradient, a drop box can be constructed. Figure 1-9 shows components for an ephemeral channel crossing. Adequate cover over the culvert is needed, the rule being a minimum of one foot or half the culvert diameter, whichever is greater. If adequate cover cannot be achieved, then an arch pipe, “squashed pipe,” or two smaller culverts should be installed. Table 1-2 provides information on culvert sizing.

**Maintenance:** Check for erosion of bank near inlet and erosion of fill. Inspect for obstructions or objects directly up the channel that could be washed into the culvert. Rip-rap or armor fill surrounding the culvert opening as needed.

**Figure 1-9—Culvert Used for Crossing Channel**

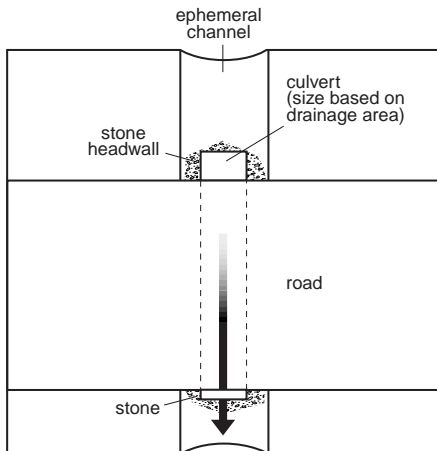

**Table 1-2—Recommended Pipe Diameters for Streams and Ephemeral Channels**

Area above Pipe (acres)	Recommended Pipe Diameter (inches)
2	12
4	15
7	18
12	21
16	24
27	30
47	36
64	42
90	48
120	54
160	60
205	66
250	72
350	78

### **Hollow Logs**

**Use:** Hollow logs can be used only for temporary crossing of ephemeral channels or small streams since they have a shorter life span than man-made culverts.

### **Specifications:**

- **The butt or large end** of the log should be placed **downstream**, to avoid premature obstruction within the log.
- **Use several logs**, if possible, to increase the capacity and allow flow if one becomes obstructed.
- **Provide adequate soil coverage** to avoid collapse under normal traffic conditions.
- **Oversize** logs relative to man-made culverts.

**Maintenance:** Same as culverts. Hollow log crossings should be removed after use.

## **Fords**

**Use:** General use for stream crossings where bottom material is firm.

**Specifications:** For permanent-use roads, fords should be graveled on each side where significant soil disturbance may occur. The road should have a reverse grade structure or other water diversion to prevent water from running down the road into the stream during high flows. Fill areas and disturbed banks in the vicinity of stream crossings should be stabilized promptly.

**Maintenance:** Maintain proper stabilization of banks. Ensure that up-slope road drainage structures are adequately maintained to avoid surface drainage into stream.

## **Low Water Crossings**

**Use:** General stream crossings.

**Specifications:** The Division of Water (502-564-3410) has developed a standard design that is typically acceptable for issuance of a floodplain permit. This design is available on request. See Streams and Other Waters BMP No. 1 and Appendix A.

**Maintenance:** Maintain proper stability of banks. Ensure that up-slope road drainage structures are adequately maintained to avoid surface drainage into stream. Regularly inspect structural aspects of crossings, especially after high water.

### *Minimum Requirement:*

<p>Do not operate skidders or other logging equipment off hard-surfaced roads under conditions that may cause the development of excessive rutting.</p>
---

Excessive rutting is defined as a point where ruts cannot be resurfaced with available equipment.

## **Landing or Log Deck Location**

*Minimum Requirement:*

Locate yards and landings outside of SMZs. Yards and landings should have adequate drainage.

**Note:** See BMP No. 3 Streamside Management Zones for further information.

## **Soil and Logging Slash**

*Minimum Requirements:*

- Disturbed soil or concentrated logging slash should not be left in ephemeral channels.
- Tops or other logging debris which may block stream channels should be removed or placed in such a way that they will not cause a blockage.

**Note:** See BMP No. 5 for further information on disturbed soil, logging slash, and trash.

## **Controlling Erosion and Runoff from Active Skid Trails**

The following guidelines will aid in proper skid trail construction.

- **Grades:** Keep skid trail grades as low as topography will permit. Do not go straight up the slope but proceed on a slant or zig-zag path and avoid long, steep slopes.
- **Ephemeral channels:** Where possible, use culverts, temporary bridges, or other structures at ephemeral channels.

- **Stream crossings:** Minimize the number of stream crossings. Where crossings are needed, properly install bridges, culverts, or use fords or low water crossings at right angles.
- **Drainage:** All trails should have drainage using turnouts and natural dips. Allowing water to accumulate on trail surfaces may lead to unwanted flows into streams or channels.
- **Bank seeps** need drainage control structures (which can be skidded across) immediately below them.
- **Extra steep skid trails** need drainage control structures (which can be skidded across) immediately above them.
- **Skidding over wet soils** may cause excessive rutting and should be avoided, if possible. Excessive rutting can be practically defined as a depth exceeding the ability of the available equipment to resurface the trail.
- **Maintenance** includes preventing water from accumulating on trails. **Berms** of dirt pushed up along the edge of trails often prevents water from draining and should be periodically removed. **Temporarily unused trails** need to have drainage control structures constructed to prevent rill and gully erosion.

*Minimum Requirements:*

- Do not operate skidders or other logging equipment off hard-surfaced roads under conditions that may cause the development of excessive rutting. Excessive rutting is defined as a point where ruts cannot be eliminated with available equipment.
- Disturbed soil or concentrated logging slash should not be left in ephemeral channels.
- Install water bars, culverts, or other drainage structures at appropriate intervals.

## **Skidding in Streams**

### *Minimum Requirement:*

Stream beds should not be used as roads or for the skidding of logs except where the geology or other physical conditions of the site (rock walls, notches, or other limiting factors) leave no other alternatives for access, or where skid trail placement in normally recommended locations is either impossible or will cause a higher degree of water quality degradation. If an exception due to physical site conditions is necessary, stream channels may be used as roads or for skidding only for the minimum distance required.

## Retirement

### *Access Roads and Landings*

Access roads or landings should be retired if further use is not planned.

- **Smooth and reshape** surfaces and banks, and remove ruts and berms.
- **Revegetate** disturbed areas as soon as is practical. See BMP No. 2 for recommended seeding mixes and treatments.
- **Control vehicle access** on retired roads until cover is established and the road has settled.
- **Open-topped culverts** should be removed and replaced with closed culverts or reverse-grade structures. These structures should be of sufficient size to carry maximum runoff to prevent them from being washed out. See “Pipe Culvert” specification.
- **Out-sloping** or returning to original contour can also be used for the retirement of access roads.
- **Disturbed soil should not be left in ephemeral channels.**
- **Logging debris and fill** should not be pushed over stream banks or left so that they will enter streams or other waters (see BMP No. 5).

### *Skid Trails*

On completion of the skidding operation **or a seasonal shut-down**, trails should be retired.

- **Water bars:** A reverse grade drainage control structure designed specifically for skid trails can be used (**Figure 1-10**). A skidder bar, shown in **Figure 1-11**, is an alternative to water bars and can be constructed with wheeled skidders. **Table 1-3** provides recommended spacing for water and skidder bars.
- **Out-sloping:** Skid trails can be out-sloped or returned to original contour to minimize or permanently eliminate or reduce erosion.

- **Stream crossings:** At stream crossings, the stream beds should be cleaned of debris and restored to natural shape and grade.
- **Revegetation:** Skid trail sections having bare soil (primary skid trails) should be revegetated in a similar manner to access roads. See BMP No. 2 for details.
- **Ephemeral channels:** Remove disturbed soil or concentrated logging slash from ephemeral channels.
- **Access** must be controlled or restricted on retired trails to allow settling and revegetation.

**Table 1-3—Recommended Distances<sup>1</sup> between Water Bars for Retirement of Skid Trails**

Skid Trail Percent	Spacing (slope distance in feet)
1	400
2	245
5	125
10	78
15	58
20	47
25	40
30	35
35	32
40	29

1 Actual distance between water bars will depend upon the nature of the road surface material, its tendency to erode, and hydrologically active areas, such as seeps.

**Figure 1-10–Water Bars (or Deep Water Breaks) for Skid Trail Retirement**

top view

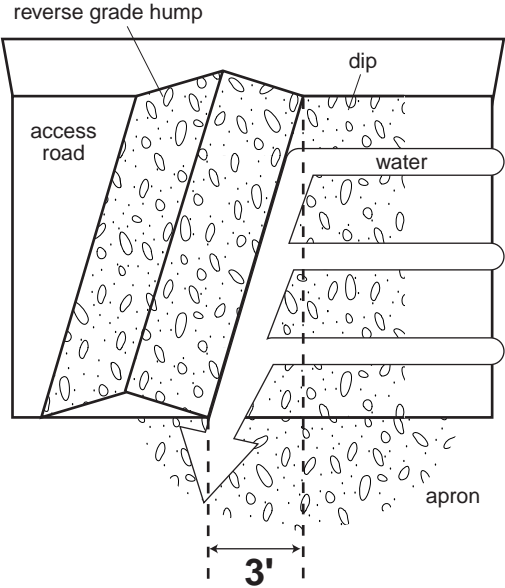

side view

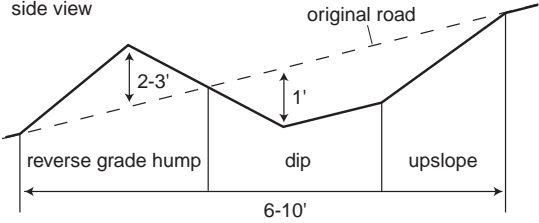

Note: These drawings are not drawn to scale.

The **skidder bar** has been designed as an alternative structure. Figure 1-11 shows the sequence of pushes used to create the skidder bar as well as the design specifications.

This structure is developed from a series of 1- to 2-foot tall piles. These piles are developed by the skidder scraping surface soil. Do not attempt to dig the dip below the hard packed surface of the trail. Overlapping the piles is critical to prevent leakage. The final push clears the berm to allow drainage.

**Figure 1-11-Skidder Bars**

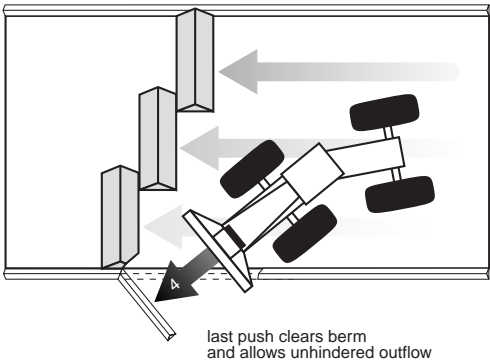
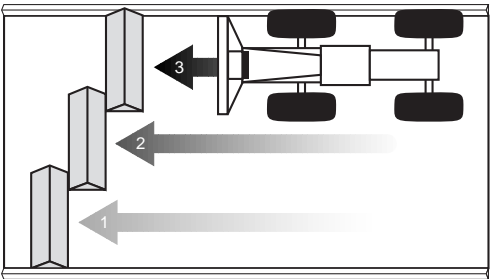
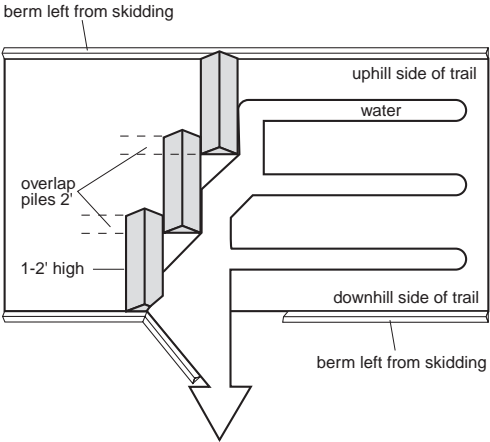

## BMP No. 2

# Vegetative Establishment of Silviculturally Disturbed Areas

---

Establishment of grass and herb cover on disturbed areas, including roads, trails, and landings, is used to stabilize the soil and reduce damage to downstream areas from sediments and runoff.

### *Minimum Requirement:*

Revegetate erodible or severely eroded areas, such as logging roads, skid trails, and log landings, as soon as possible. Revegetation should be sufficient to adequately control or significantly abate erosion from the site.

This BMP uses both temporary cover species and a mixture of permanent species to revegetate disturbed areas.

- **Temporary cover species** are those that come up quickly and vigorously and act to provide a rooting mass until the permanent mixtures take hold.
- **Permanent mixes** are a combination of compatible grass and legume species that will become established and grow for a number of years on a site until natural seeding can occur.

### **Prepare for Seeding**

**Smooth and shape** the site to permit the use of equipment for seedbed preparation. **Seedbed preparation** is generally needed and can be accomplished by practices such as disking. In cases where this is not practical and the soil surface is glazed or crusted, the surface should be roughened before lime, fertilizer, and seed are applied.

## Using the Seeding Tables

Use the following tables to help determine what temporary species (Table 2-1) and permanent mixes (Tables 2-2 to 2-5) to use. **In all cases, a temporary species is to be used with a permanent mix.** Each species or mix has a specific seeding date.

- **Species:** The species or mixes in **bold** are generally the most effective.
- **Seeding dates:** For permanent mixtures, seeding dates are for the entire mixture. For example, the seeding dates in Table 2-2 recommend that mixture “a” be seeded between February 1 and May 1, or between August 1 and October 15.
- **When seeding must be accomplished outside of the recommended seeding windows, it is recommended that seeding rates be increased by 50 percent and mulch be used.**
- **Seeding rates:** lbs/ac/pls. refers to *pounds of pure live seed per treated acre* (see Determining Pure Live Seed section). Some species come with germination or purity information. Make the appropriate adjustment in seeding rates (see infor-

**Table 2-1—Temporary Cover Crop Species**

Species	Seeding Rates (lbs/ac/pls <sup>1</sup> )	Recommended Seeding Dates
<b>winter wheat</b> <sup>2</sup>	35	Oct. 15 - March 1
<b>grain rye</b>	35	Oct. 15 - March 1
<b>spring oats</b>	35	Oct. 15 - March 1
foxtail millet	12	May 1 - July 15
Japanese millet	15	May 1 - July 1
pearl millet	10	May 1 - July 1
annual ryegrass	5	Aug. 1 - Oct. 15
browntop millet	15	May 1 - July 1
cereal rye (Aroostook)	25	Sept. 15 - Oct. 15

1 pls: pure live seed (see Appendix 1 in this BMP).

2 Species in **boldface type** are primary recommendations.

mation in Mulching, Fertilizer, and Seeding Section of this BMP).

- **Special considerations:** Some mixes have special light requirements or restricted seeding dates. Consider these special needs when selecting a mix.

**Table 2-2—Mixtures for Slopes Less than 10 Percent**

Species Mixture	Seeding Rates (lbs/ac/pls <sup>1</sup> )	Seeding Dates for Mixture <sup>2</sup>	Special Considerations
a. <b>orchard grass</b> <sup>3</sup>	8	Feb. 1 - May 1 Aug. 1 - Oct. 15	
red clover	6		
b. <b>orchard grass</b>	8	Feb. 1 - May 1 Aug. 1 - Oct. 15	
ladino clover	2		
c. timothy	4	Feb. 1 - May 1 Aug. 1 - Oct. 15	
ladino clover	2		
d. <b>orchard grass</b>	10	Feb. 1 - May 1	No fall planting due to lespedesa
<b>Kobe or Korean lespedesa</b>	10		
e. switch grass	1	May 1 - June 30	For open canopy conditions only. A good seed bed is required. No fall planting due to lespedesa.
big bluestem	2		
indiangrass	2		
red clover	4		
Korean lespedesa	5		
f. little bluestem	3	May 1 - June 30	No fall planting due to lespedesa
side-oats	3		
gramma			
Korean lespedesa	5		

- 1 pls: pure live seed (see Appendix 1).
- 2 The seeding dates were developed for the mixture and not the individual species. For example, it is recommended that mixture "a" be seeded between February 1 and May 1 or between August 1 and October 15.
- 3 Mixtures in **boldface type** are primary recommendations.

**Table 2-3—Mixtures for Highly Erodible Areas (Areas Exceeding 10 Percent Slope)**

Species Mixture	Seeding Rates (lbs/ac/pls) <sup>1</sup>	Seeding Dates <sup>2</sup> for Mixture	Special Considerations
a. <b>Kentucky 31 fescue</b>	30	Feb. 1 - May 15 Aug. 1 - Oct. 15	High seedling and plant vigor on droughty, exposed sites. The endophyte-free fescue is more valuable for wildlife and is acceptable on lesser slopes.
<b>flatpea</b> <sup>3</sup>	30		
b. <b>Kentucky 31 fescue</b>	30	Feb. 1 - May 15 Aug. 1 - Oct. 15	High seedling and plant vigor on droughty, exposed sites. The endophyte-free fescue is more valuable for wildlife and is acceptable on lesser slopes.
<b>birdsfoot trefoil</b>	10		
c. <b>creeping red fescue</b>	20	Feb. 1 - May 15 Aug. 1 - Oct. 15	<b>For use in shaded areas.</b>
<b>white clover</b>	2		
d. switch grass	8	May 1 - June 30	For open canopy conditions only. Switch grass is a native.
partridge pea	5		

1 pls: pure live seed (see Appendix 1).

2 The seeding dates were developed for the mixture and not the individual species. For example, it is recommended that mixture "a" be seeded between February 1 and May 1, or between August 1 and October 15.

3 Mixtures in **boldface type** are primary recommendations.

**Table 2-4—Mixtures for Wet or Poorly Drained Areas**

Species Mixture	Seeding Rates (lbs/ac/pls) <sup>1</sup>	Seeding Dates <sup>2</sup>	Special Considerations
a. <b>redtop</b>	7	Feb. 15 - June 30 Aug. 1 - Oct. 1	
<b>alsike clover</b> or <b>birdsfoot trefoil</b> <sup>3</sup>	6		
b. switch grass	8	May 1 - June 30 Aug. 1 - Oct. 1	For open canopy conditions only.
alsike clover or birdsfoot trefoil	6		

1 pls: pure live seed (see Appendix 1).

2 The seeding dates were developed for the mixture and not the individual species. For example, it is recommended that mixture "a" be seeded between February 15 and June 30, or between August 1 and October 1.

3 Mixtures in **bold face type** are primary recommendations.

**Table 2-5—Mixtures for Establishing Native Species**

Species Mixture	Seeding Rates (lbs/ac/pls) <sup>1</sup>	Seeding Dates <sup>2</sup>	Special Considerations
a. switch grass	2.0	May 1 - June 30	For open canopy conditions only.
indiangrass	2.0		
big bluestem	1.5		
little bluestem	1.5		
partridge pea	5.0		

1 pls: pure live seed (see Appendix 1).

2 The seeding dates were developed for the mixture and not the individual species. For example, it is recommended that mixture "a" be seeded between February 1 and May 1, or between August 1 and October 15.

## **Mulching, Fertilizing, Liming, and Seeding**

- **General fertilization** at a rate of 70 to 80 pounds of nitrogen (N), 120 pounds of phosphorus (P<sub>2</sub>O<sub>5</sub>), and 120 pounds of potassium (K<sub>2</sub>O) per acre is normally adequate.
- **For native grasses**, no more than 40 to 50 pounds of nitrogen should be applied at planting to avoid excessive competition. Two to three tons of agricultural ground limestone per acre are generally adequate where liming is indicated.
- **Work the fertilizer and lime into the soil** with a harrow, disk, or rake operated across the slope.
- **Mulch** will aid in most situations. Table 2-6 provides information on amounts and coverage of mulch. It is particularly important in the following situations:
  - Areas which are steep, eroding, or are difficult to revegetate.
  - Seeding outside the seeding dates.

**Table 2-6—Mulching Materials, Rates, and Uses**

<b>Mulch Material and Quality</b>	<b>Rate Per 1000 Sq. Ft.</b>	<b>Acre</b>	<b>Remarks</b>
a. small grain straw, tall fescue straw, or hay	75-100 lbs (1½-2 bales)	1½ tons (60-80 bales)	Spread uniformly. Leave 10-20% of the area exposed. Subject to wind blowing unless left moist or tied down.
b. wood fiber cellulose air-dried, non-toxic, and no growth-inhibiting substances	37-41 lbs	1600-1800 lbs	Apply with a hydro-mulcher. No tie-down is required. Packaged in 100 lb. bags.
c. tree bark air-dried, non-toxic, and no growth-inhibiting substances		6-12 tons	Resistant to wind blowing. Decomposes slowly.

See Appendix 1 in this BMP for determination of land area where mulching is needed.

## Determining Ground Area and Pure Live Seed

**Table 2-7—Road and Trail Surface Area Determination for Fertilizer, Seed, Lime, and Mulch**

<b>Road Length (feet)</b>	<b>Road Width (feet)</b>				
	<b>8</b>	<b>10</b>	<b>12</b>	<b>14</b>	<b>18</b>
	<b>acres</b>				
<b>50</b>	.01	.01	.01	.02	.02
<b>100</b>	.02	.02	.03	.03	.04
<b>250</b>	.05	.06	.07	.08	.10
<b>500</b>	.09	.12	.14	.16	.21
<b>750</b>	.14	.17	.21	.24	.31
<b>1000</b>	.18	.24	.28	.32	.41
<b>1500</b>	.28	.34	.41	.48	.62
<b>2000</b>	.36	.48	.56	.64	.83
<b>5000</b>	.92	1.15	1.38	1.16	2.07
<b>5280</b>	.97	1.21	1.45	1.70	2.18

## **Determining Acreage for Irregularly Shaped Areas**

To determine acreage and pounds of seed for other areas, such as log landings or denuded areas, use the following procedure:

1. Measure the width across the area in several locations and determine the average width.
2. Measure the length of the area in several locations and determine the average length.
3. Multiply the average width by the average length to get the square feet of disturbed area.
4. Divide the square feet of disturbed area by 43,560 feet per acre to get the acreage.
5. Multiply the acreage of the area by the recommended amount of seed per acre to determine the amount of seed required.

## **Determining Pure Live Seed**

Pure Live Seed is determined by multiplying percent germination by percent purity. Divide result into recommended pounds of seed per acre which gives the bulk seed needed. Example: fescue may have 98 percent purity and 80 percent germination. If you need to seed 40 pounds per acre of pure live seed, the procedure would be:

$$0.98 \text{ purity} \times 0.80 \text{ germination} = 0.784$$

$$\frac{40 \text{ lb/ac}}{0.784} = \mathbf{51 \text{ lb of seed needed}}$$

## **Regulatory Requirements for BMP No. 2**

*(See Appendix A for Explanations)*

- All silvicultural operations: **(410 KAR 5:026, 5:029, 5:030, and 5:031)**
- Activities near high-quality waters and outstanding national resource waters: **(401 KAR 5:029, 5:030, and 5:031)**
- Activities near wild rivers: **(KRS 146.200 et seq. and 401 KAR 4:100-140)**

# **BMP No. 3**

## **Streamside Management Zones**

---

**Streamside Management Zones (SMZs)** are areas adjacent to intermittent (flowing only during the wet portions of the year and/or in response to rain events), perennial waters (containing water throughout the year), and other waters where only limited disturbance is desirable. Floodplains are flat areas directly adjacent to streams where periodic flooding occurs. SMZ specifications are different for each type of water and include:

- width of trees and amount of overstory trees to be left next to the stream bank;
- distance of disturbed ground to stream bank (unless crossing).

### **Use of Stream Beds for Roads and Skid Trails**

*Minimum Requirement:*

Stream beds should not be used as roads or for the skidding of logs except where site conditions (rock walls, notches, or other limiting factors) leave no other alternatives for access or where road or skid trail placement in normally recommended locations is either impossible or will cause a higher degree of water quality degradation.

### **Perennial Streams, Lakes, and Ponds**

Perennial waters contain water throughout the year. Recommendations are given for four types of perennial waters including:

1. Regular streams and other waters including lakes and ponds (Warm Water Aquatic Habitats).

2. Coldwater Aquatic Habitats (identified as those water bodies having the potential to carry trout).
3. Streams, sloughs, and ponds in wetlands.
4. Specially designated waters.

## 1. Regular Streams and Other Waters (Warm Water Aquatic Habitats)

### *Minimum Requirements:*

- In areas adjacent to perennial streams, lakes, and ponds, maintain forest buffers for a **surface** distance of 25 feet on ground with less than 15 percent slope and for a minimum **surface** distance of 55 feet on ground with slope of 15 percent or greater where possible.
- At least 50 percent of the original tree **overstory** should be retained to shade the water.

**Table 3-1—Specifications for Regular Streams and Other Waters**

Slope of Ground Next to Bank	Width of Trees (Surface Distance)	Overstory Trees Retained	Understory Trees and Shrubs	Distance of Disturbed Ground to Bank
less than 15 percent	25 feet	50 percent	minimal disturbance	see Table 3-1
greater than 15 percent	55 feet			

**Table 3-2—Minimum Distances from Perennial Water Bodies to Roads, Trails, or Landings<sup>1</sup>**

Slope of Land (%) Away from Stream Bank	Width of Zone (feet) Away from Stream Bank
0	25
5	35
10	45
15	55
20	65
25	75
30	85
35	95
40	105
50	125
60	145
70	165

<sup>1</sup> Where minimum distances are not possible, roads, trails, and landings can be located at less than the recommended distances, but they should be constructed to protect water quality.

**Figure 3-1—Streamside Management Zone Specifications for Perennial Warm Water Aquatic Habitats**

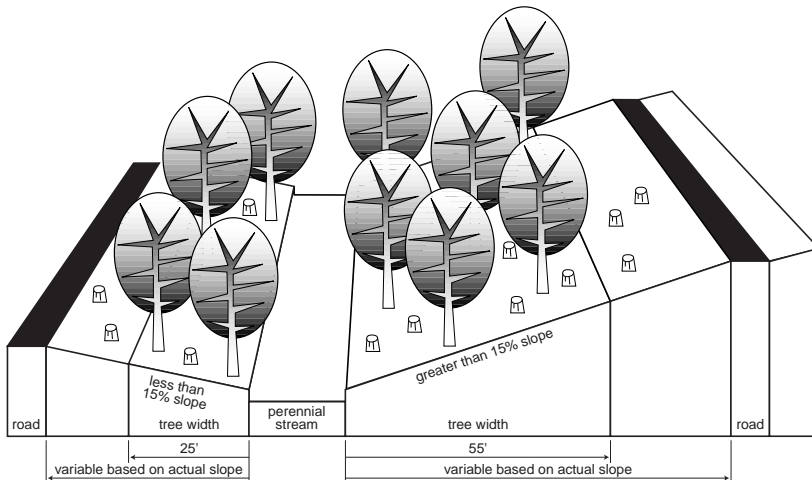

**2. Coldwater Aquatic Habitats (CAHs)** See Appendix B for locations of Coldwater Aquatic Habitats.

*Minimum Requirements:*

- These streams should have a minimum of 75 percent of the original tree overstory retained within the 60-foot-wide strip on either side of the stream to provide shade. CAHs should have only individual trees or trees in small groups removed.
- Understory vegetation immediately adjacent to CAH streams should be left undisturbed.

**Table 3-3—Specifications for Coldwater Aquatic Habitats**

<b>Width of Trees (Surface Distance)</b>	<b>Overstory Trees Retained</b>	<b>Understory Trees and Shrubs</b>	<b>Distance of Disturbed Ground to Bank</b>
60 feet regardless of slope	75 percent	no disturbance	see Table 3-1

**3. Perennial Streams, Ponds, and Sloughs in Wetlands.** Also see BMP No. 10 for further information on wetlands.

*Minimum Requirement:*

Leave a minimum of 50 percent of the overstory trees to shade perennial streams, ponds, and sloughs.

**Figure 3-2. Streamside Management Zone Criteria for Streams and Sloughs in Wetlands**

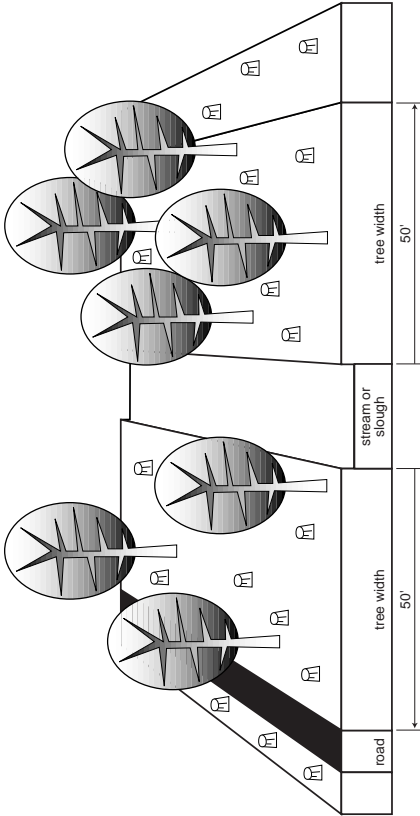

**Table 3-4—Specifications for Perennial Streams, Ponds, and Sloughs in Wetlands**

Width of Trees (Surface Distance)	Overstory Trees Retained	Understory Trees and Shrubs	Distance of Disturbed Ground to Bank
50 feet regardless of slope	50 percent	minimal disturbance	50 feet (unless crossing)

**4. Specially Designated Perennial Waters.** Certain streams and rivers are designated for special protection, including:

- **Wild Rivers:** See Appendix C for Wild River Locations. Contact the Kentucky Division of Water's Wild Rivers Program (502-564-3410) before logging along a corridor of a Wild River.
- **High-quality Waters:** See Appendix D for locations of these waters. Special care and strict adherence to BMPs should be used in and around these waters.
- **Outstanding National Resource Waters:** See Appendix E for locations of these waters. Special care and strict adherence to BMPs should be used in and around these waters.

### **Intermittent Streams**

Intermittent streams flow only during the wet portions of the year and in response to rain events.

#### *Minimum Requirement:*

In areas adjacent to intermittent streams, avoid equipment operation in a zone of at least 25 feet on each side of an intermittent stream except for designated crossings, where possible. Tops or other logging debris that may block the intermittent stream channel should be removed or placed in such a way that they will not cause a blockage.

**Table 3-5—Specifications for Intermittent Streams**

<b>Width of Trees</b>	<b>Overstory Trees Retained</b>	<b>Understory Trees and Shrubs</b>	<b>Distance of Disturbed Ground to Bank</b>
0 feet	0 percent	minimal disturbance	see Table 3-6 (unless crossing)

**Table 3-6—Minimum Distances from Intermittent Streams to Roads, Trails, or Landings<sup>1</sup>**

Slope of Land (%) Away from Stream Bank	Width of Zone (feet) Away from Stream Bank
0	25
5	30
10	35
15	40
20	45
25	50
30	55
40 or higher	65

<sup>1</sup> Where minimum distances are not possible, roads, trails, and landings can be located at less than the recommended distances, but they should be constructed to protect water quality.

**Figure 3-3—Streamside Management Zone Specifications for Intermittent Streams**

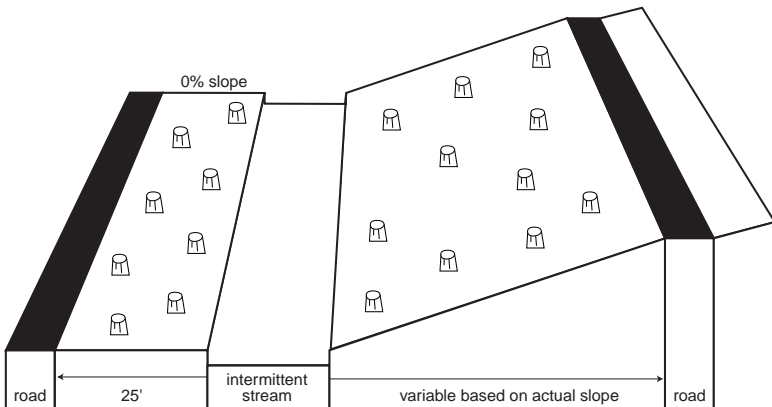

**Important:** While no standing tree width is required, tree tops cannot be left in intermittent streams and should not be placed so as to wash into a stream. Use a standing tree zone to lodge tops, if necessary. Floodplain Regulations may apply (See Appendix A).

### **Floodplains**

See floodplain regulations in Appendix A for requirements necessary for building crossings. Tree tops and debris should not be left so they could obstruct water flow in perennial or intermittent streams.

- Tree tops and logging debris generated along streams should be winched and lodged in or behind the standing trees of an SMZ.

### **Regulatory Requirements for BMP No. 3**

*(See Appendix A for Explanations)*

- Debris in floodplains: **(KRS 151.250)**
- All silvicultural operations: **(410 KAR 5:026, 5:029, 5:030, and 5:031)**
- Activities near high-quality waters and outstanding national resource waters: **(401 KAR 5:029, 5:030, and 5:031)**
- Activities near wild rivers: **(KRS 146.200 et seq. and 401 KAR 4:100-140)**

# BMP No. 4

## Sinkholes

The purpose of this BMP is to minimize nonpoint source pollutants from flowing into sinkholes.

**Figure 4-1—Flow of Waters through a Sinkhole**

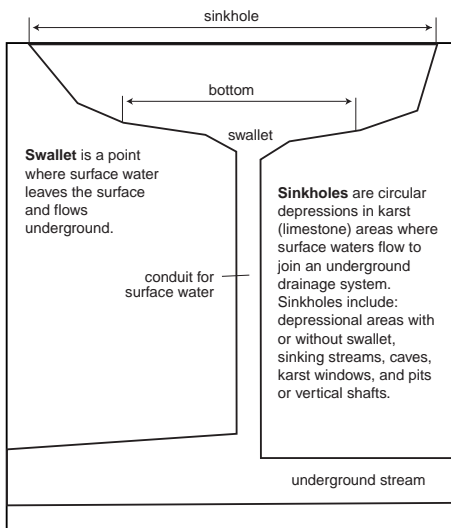

### **Soil, Logging Debris, Fluids, and/or Other Waste Materials**

#### *Minimum Requirements:*

Fluids from equipment should not be drained onto the ground. They should be collected in a container, transported off site, and recycled or disposed of properly. Soil, logging debris, and/or other waste materials should not be pushed into the bottom of a sinkhole or into any noticeable sinkhole opening.

## **Sinkhole Buffer Zones**

### *Minimum Requirements:*

- Divert runoff from haul/access roads, skid trails, and log landings so it does not drain directly into sinkholes, sinking streams, or caves. If runoff does enter a sinkhole, a UIC permit (see Modified Sinkholes in Appendix A, contact Division of Water 502-564-3410) may be required.
- Leave a buffer zone between any disturbed area and the open swallet of a sinkhole. Buffer zones should be 30 feet for areas of 5 percent slope, and an additional 10 feet in width should be added to this zone for each 10 percent increase in slope.

## **Regulatory Requirements for BMP No. 4**

*(See Appendix A for Explanations)*

- Activities around sinkholes, cave entrances, etc.: **(KRS 433.870-433.875)**
- Endangered species in caves: **(Federal Register 55:6184 and 56:58804-58836)**
- Modified sinkholes: **(May need to be registered and/or permitted)**
- Cave streams and other underground surface waters: **(may deal with KY Surface Water Statutes and/or Outstanding Resource Waters)**
- All silvicultural operations: **(410 KAR 5:026, 5:029, 5:030, and 5:031)**
- Activities near high-quality waters and outstanding national resource waters: **(401 KAR 5:029, 5:030, and 5:031)**
- Activities near wild rivers: **(KRS 146.200 et seq. and 401 KAR 4:100-140)**
- Karst groundwater basin protection

**Table 4-1—Minimum Distances from Silviculturally Disturbed Areas and the Point of Lowest Elevation or Open Swallet of a Sinkhole**

Slope of Land (%)	Distance (Feet)
5	30
10	35
20	45
30	55
40 or higher	65

Note: This table corresponds to the recommended minimum distances for roads, trails, and landings from intermittent streams.

**Figure 4-2—Specifications for Sinkhole BMP**

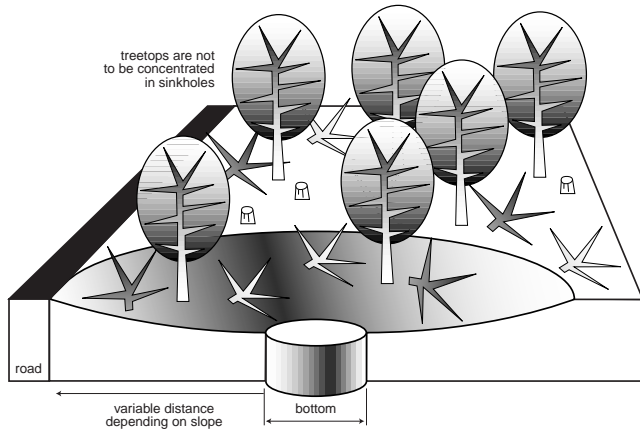

## **BMP No. 5**

### **Logging Debris**

---

To protect water bodies from pollution by debris and disturbed soil from timber harvests.

#### **Tree Debris**

Trees and brush can be potential water pollutants. The breakdown of logging debris left in the water can decrease oxygen and in addition may create other problems of odor, color, and excessive nutrients.

#### *Minimum Requirement:*

Tree debris, such as tops, should not be left in or allowed to wash into perennial streams.
---

In order to keep logging debris (including tree tops, limbs, etc.) from washing into perennial and intermittent streams, lakes, or ponds, move the debris a sufficient distance from the bank or locate the debris to ensure it does not move back into the water bodies. See BMP No. 3 for further details.

#### **Equipment Fluids**

Hydraulic fluids, gas, oil, and antifreeze represent potential sources of water pollution.

#### *Minimum Requirement:*

Equipment should not be left on stream banks or equipment fluids should not be changed in such a manner where pollutants may wash into a stream. Properly dispose of used oil, hydraulic fluids, and other fluids.
--

## **Other Garbage and Waste**

### *Minimum Requirement:*

Properly dispose of cans, bottles, lunch bags, oil filters or air filters, etc.
---

## **Regulatory Requirements for BMP No. 5**

*(See Appendix A for Explanations)*

- All silvicultural operations: (**410 KAR 5:026, 5:029, 5:030, and 5:031**)
- Debris in floodplains: (**KRS 151.250**)
- Activities near high-quality waters and outstanding national resource waters: (**401 KAR 5:029, 5:030, and 5:031**)
- Activities near wild rivers: (**KRS 146.200 et seq. and 401 KAR 4:100-140**)

# BMP No. 7

## Fertilizers

---

**Fertilization** can aid in the establishment of herbaceous vegetation used to stabilize disturbed soil. Fertilizer includes both organic waste and industrially produced liquid, granular, or powdered formulations of plant nutrients. Improper use of fertilizer may result in excessive nutrients in nearby waters.

### *Minimum Requirements:*

- Use only the amount of fertilizer necessary, and stay away from bodies of water or those areas immediately adjacent to them.
- Avoid using fertilizers in SMZs.
- Avoid using fertilizers within 30 feet of any noticeable sinkhole opening.

### **Regulatory Requirements for BMP No. 7**

*(See Appendix A for Explanations)*

- Application of sludge: **(May require a permit)**
- All silvicultural operations: **(410 KAR 5:026, 5:029, 5:030, and 5:031)**
- Activities near high-quality waters and outstanding national resource waters: **(401 KAR 5:029, 5:030, and 5:031)**
- Activities near wild rivers: **(KRS 146.200 et seq. and 401 KAR 4:100-140)**

# **BMP No. 10**

## **Timber Harvesting in Wetland Areas**

---

**Wetlands** are areas characterized by soils saturated with moisture during all or a large portion of the year and support a number of plants that grow in wet soils. **The requirements in this BMP are supplemental to other BMPs and contain information and specifications for trafficking and timber harvesting around streams, sloughs, and other waters in a wetland.**

### **Determining Wetland Areas**

Official determination of whether a forested area is a wetland is the responsibility of the U.S. Army Corps of Engineers, unless there is adjacent cropland, in which case the determination may be made by the Natural Resources Conservation Service. Contact the Kentucky Division of Forestry, Natural Resources Conservation Service, or Cooperative Extension Service (see Appendix F) for assistance in determining wetlands.

### **Constructing Roads, Trails, Landings**

Road construction is the activity most likely to cause changes in the drainage of wetlands. When needed, locate roads on the higher ground or “ridges” and parallel to the drainage system, and use a minimum amount of fill material. Locate log decks on elevated areas away from streams as far as is practical. Keep log landings small and few in number.

*Minimum Requirement:*

Minimize construction of permanent roads, locate landings on higher ground, and restrict vehicle traffic to a minimum.

## **Crossing Streams and Sloughs**

*Minimum Requirement:*

Avoid crossing of streams and sloughs, if possible.

When unavoidable, cross at right angles. Use culverts and bridges without altering natural drainage and without disturbing stream banks and other sensitive areas.

**Retire** temporary roads, trails, and landings (see BMP No. 1 and No. 2).

## **Streamside Management Zones (SMZs) in Wetland Areas**

*Minimum Requirement:*

Leave a minimum of 50 percent of the overstory trees to shade perennial streams and sloughs.

- **Retain an overstory tree width** of at least 50 feet.
- **A least 50 percent** of the overstory trees should be retained with the tree width (see details in BMP No. 3).
- **Operation of logging vehicles** and equipment should be minimized in SMZs.

## **General Felling and Skidding**

- **Remove tops of harvested trees** from streams and sloughs to allow unrestricted water flow.
- **Plan harvesting during dry weather.** Wetlands are particularly sensitive to rutting.
- **Use low ground pressure tires on skidders,** when available, and concentrate skidding as much as possible on a few primary skid trails to minimize site disturbance and compaction.
- **Roughen severely compacted areas** on landings and skid trails.

## **Regulatory Requirements for BMP No. 10**

*(See Appendix A for Explanations)*

- Filling or draining of wetland: (**33 USC 1251 et seq., Section 404**)
- All silvicultural operations: (**410 KAR 5:026, 5:029, 5:030, and 5:031**)
- Activities near high-quality waters and outstanding national resource waters: (**401 KAR 5:029, 5:030, and 5:031**)
- Activities near wild rivers: (**KRS 146.200 et seq. and 401 KAR 4:100-140**)

# **Streams and Other Waters BMPs**

---

Details of these BMPs can be obtained from the Kentucky Agriculture Water Quality Authority Produce Workbook. The minimum requirements for each of the four Streams and Other Waters BMPs are as follows:

## **BMP #1—Stream Crossing Protection**

- Construct low water crossings in a manner that does not obstruct the normal flow of the stream.
- Minimize soil erosion and removal of streamside vegetation.

## **BMP #2—Sand and Gravel Removal**

- Minimize disturbance to streams by excavation equipment and access gravel from shore as much as possible.

## **BMP #3—Stream Bank and Shoreline Protection**

This includes requirements for stream bank stabilization for banks which are eroding at an accelerated rate and stream crossings that might be damaged by vehicular traffic.

## **BMP #4—Proper Stream Drainage Maintenance**

Specifies requirements for clearing logjams or sediment blockage as follows:

For projects in streams where the watershed above the work is less than one square mile (640 acres):

- Focus work only in areas where problems occur and avoid unnecessary disturbance to adjacent stream habitat.
- Minimize the removal of streamside vegetation. Remove only the necessary vegetation and operate equipment from only one side of the stream.
- Minimize straightening of stream meanders.
- When working in streams that have been channelized, consult the NRCS and the Kentucky Division of Water.
- Care should be taken to avoid impacts to wetlands adjacent to streams (see special note on Corps of Engineer notification in Producer Workbook).

For projects in streams where the watershed above the work is more than one square mile (640 acres), assistance must be obtained from sources such as: the U.S. Army Corps of Engineers, USDA Natural Resource Conservation Service, private consultants, etc., and the Kentucky Division of Water. The Kentucky Division of Forestry and County Agent offices can help identify the appropriate sources in your area.

# Appendix A

## Regulatory Requirements

### All Silvicultural Operations, 401 KAR 5:026, 5:029, 5:030, and 5:031

---

All operations must meet Kentucky water quality standards.

**Activities Near High-quality Waters and Outstanding National Resources Waters, 401 KAR 5:029, 5:030, and 5:031.** Kentucky water quality standards (401 KAR 5:029) require the use of BMPs to protect high-quality waters and outstanding national resources waters listed in 401 KAR 5:030. In addition, outstanding resource waters that support federally listed threatened and endangered species require protection (see 401 KAR 5:031).

**Activities Near Wild Rivers, KRS 146.200 et seq. and 401 KAR 4:100-140.** The Kentucky Wild Rivers Act and associated regulations give special protection to streams designated as “wild rivers,” including regulation of silvicultural activity. Before undertaking any silvicultural activity in a corridor of a designated wild river, the landowner or logger should contact the Wild Rivers Program of the Kentucky Division of Water for applicable regulations and instructions.

**Debris in Floodplains, KRS 151.250.** The Kentucky Division of Water has authority over the placement of debris (including logging slash) in floodplains of perennial streams that have a drainage area larger than one-square mile. The Division of Water advises that as long as the BMPs for Streamside Management Zones and logging debris are followed, landowners and loggers will be considered in compliance with floodplain regulations that address debris. If these BMPs are not followed, the Kentucky Division of Water can institute enforcement proceedings.

**Construction in Floodplains, KRS 151.250.** All structures (bridges, berms, or other construction that could obstruct flood flows) that are to be constructed in the floodplain of a perennial stream that drains more than one-square mile require a floodplain permit from the Kentucky Division of Water.

**Filling or Draining of Wetlands, U.S. Clean Water Act, Section 404.** The U.S. Army Corps of Engineers regulates all filling or draining of wetlands, streams, lakes, or other bodies of water. Normal ongoing silvicultural activities, including building and maintaining forest roads, do not require individual permits, providing certain conditions are met, including adherence to the federal baseline BMPs for forest roads. For detailed information on the silvicultural exemption, contact the Kentucky Division of Forestry.

**Activities around Sinkholes and Cave Entrances, KRS 433.870-433.875.** The Kentucky Cave Protection Act offers protection to any sinkhole, pit, karst window, and/or sinking stream that has an opening large enough for a person to enter a black zone. The Federal Cave Protection Act is used to manage nonrenewable cave resources on federal lands. Management techniques include buffer zones around sinkhole and cave entrances to provide food sources for cave life, regulate thermal variations, and prevent sedimentation. Extremely sensitive karst systems can include the entire recharge area as a buffer zone.

**Endangered Species in Caves, Federal Register 55:6184-6229 and 56:58804-58836.** The Kentucky State Nature Preserves Commission maintains the list of Kentucky plants and animals that are considered endangered, threatened, and of special concern. The U.S. Fish and Wildlife Service administers the federal Endangered Species Act of 1973, as amended in 1990, and the 1991 Candidate Review. Many species protected by these acts live in caves and can be threatened by pollutants entering sinkholes.

**Modified Sinkholes.** Any sinkhole that has been modified to receive additional storm water runoff can be clas-

sified as a Class V Underground Injection Control (UIC) Well, which must be registered and/or permitted by the U.S. Environmental Protection Agency Underground Injection Control Program.

**Cave Streams and Other Underground Surface Waters.** Kentucky surface water statutes and regulations have defined subterranean streams that flow underground and have discrete banks and channels, such as cave streams, as surface waters. Several karst groundwater basins in the Mammoth Cave National Park that extend well outside of the Park's boundary have been designated as Outstanding Resource Waters and receive the same special protection of species as the blind shrimp in Mammoth Cave.

**Karst Groundwater Basin Protection.** The federal and state Wellhead Protection Programs are developing karst groundwater basin protection plans for public water supplies that use karst springs or groundwater as their water source.

**Application of Sludge.** The application of some organic materials, such as sludge, can require a permit for compliance with federal and/or state regulations. For more information regarding permits required for the application of sludge, contact the Kentucky Division of Waste Management.

**Application of Pesticides.** Use only pesticides approved by the Environmental Protection Agency for use in Kentucky. Follow all pesticide label directions. Application of some chemicals can require applicator certification and/or licensing.

# Appendix B

## Kentucky Bodies of Water Designated as Coldwater Aquatic Habitats

---

The additional protection given to SMZs bordering Coldwater Aquatic Habitats, as described in the BMP guidelines for SMZs, extends only to the main stem of listed streams.

Body of Water	Zone	County
<b>Big Sandy River Basin</b>		
Paintsville Lake	Entire Reservoir	Johnson
<b>Little Sandy River Basin</b>		
Big Caney Creek	Source to Grayson Lake	Elliott
Big Sinking Creek	River Mile 6.0 to Little Sandy River	Carter
Laurel Creek	Source to Little Sandy River	Elliott
Greenbo Lake	Entire Reservoir	Greenup
<b>Licking River Basin</b>		
Craney Creek	Source to North Fork Licking River	Rowan/Morgan
Licking River	River Mile 176.8 (Cave Run Lake Dam) to River Mile 169.6 (U.S. Highway 60 bridge.)	Bath/Rowan
<b>Kentucky River Basin</b>		
Chimney Top Creek	Basin	Wolfe
Dix River	Herrington Lake Dam to Kentucky River	Garrard/Mercer
East Fork Indian Creek	Source to Indian Creek	Menifee
Gladie Creek	Basin	Menifee
Middle Fork Red River	Source to River Mile 10.6	Powell
Parched Corn Creek	Source to Red River	Wolfe

## Appendix B *continued*

<b>Body of Water</b>	<b>Zone</b>	<b>County</b>
Swift Camp Creek	Source to Red River	Wolfe
Bert Combs Lake	Entire Reservoir	Clay
Fishpond Lake	Entire Reservoir	Letcher
Mill Creek Lake	Entire Reservoir	Wolfe
<b>Green River Basin</b>		
Beaver Dam Creek	Source to Green River	Edmonson
Buffalo Creek	Source to Green River (in Mammoth Cave National Park)	Edmonson
Lick Creek	Source to West Fork of Drakes Creek	Simpson
Lynn Camp Creek	Source to Green River	Hart
Underground River System	Mammoth Cave National Park Barren	Edmonson/Hart
	Turnhole Spring Basin	Edmonson/Barren
	Echo River Basin	Edmonson
	Pike Spring Basin	Edmonson
	Mile 205.7 Spring Basin	Hart
	McCoy Spring Basin	Hart
	Suds Spring Basin	Hart/Barren
	Nolin River	River Mile 7.6 (Nolin Lake Dam) to Green River
Rough River	River Mile 89.3 (Rough River Dam) to River Mile 72.4	Ohio/Grayson
Roundstone Creek	Source to Kentucky Highway 1140 (River Mile 3.5)	Hart
Trammel Fork	Source to Kentucky Highway 31E (River Mile 23.6)	Warren

## Appendix B *continued*

---

<b>Body of Water</b>	<b>Zone</b>	<b>County</b>
<b>Lower Cumberland River Basin</b>		
Casey Creek	Source to Little River	Trigg
Skinframe Creek	Source to Livingston Creek	Lyon
Sulphur Spring Creek	Source to Red River	Simpson
<b>Ohio River Basin</b>		
Doe Run Creek	Source to Kentucky Highway 1628 (River Mile 5.15)	Meade
Sinking Creek	Source to Kentucky Highway 259 (River Mile 4.0)	Breckinridge
<b>Upper Cumberland River Basin</b>		
Bad Branch	Basin	Letcher
Bark Camp Creek	Basin	Whitley
Beaver Creek	Basin	McCreary
Breeden's Creek	Basin	Harlan
Bunches Creek	Basin	Whitley
Cane Creek	Basin	Laurel
Cogur Fork	Basin	McCreary
Cumberland River	Lake Cumberland Dam (River Mile 460.9) to Kentucky Highway 90 bridge (River Mile 426.5)	Cumberland
Difficulty Creek	Basin	McCreary
Dogslaughter Creek	Basin	Whitley
Fugitt Creek	Basin	Harlan
Indian Creek	Source to Barren Fork	McCreary
Kelly Branch	Basin	Harlan
Laurel Creek	River Mile 9.0 to River Mile 3.4	McCreary

## Appendix B *continued*

---

<b>Body of Water</b>	<b>Zone</b>	<b>County</b>
Looney Creek	Basin above River Mile 5.3	Harlan
Martin's Fork	Basin above River Mile 27.4	Harlan
Poor Fork Cumberland River	Basin above River Mile 742.7	Letcher
Razor Fork	Basin	Harlan
Rock Creek	Tennessee/Kentucky State Line (River Mile 21.9) to White Oak Creek	McCreary
Shillalah Creek	Source to Cumberland Gap National Historical Park Boundary	Bell
Sugar Run	Source to Cumberland Gap National Historical Park Boundary	Bell
Troublesome Creek	Basin	McCreary
White Oak Creek	Basin above River Mile 1.2 (includes Little White Oak Creek)	Laurel
Wood Creek	Wood Creek Lake Dam (River Mile 4.0) to Hazel Patch Creek	Laurel
Beulah (Tyner) Reservoir	Entire Reservoir	Jackson
Cannon Creek Lake	Entire Reservoir	Bell
Laurel River Lake	Entire Reservoir	Laurel
Wood Creek Lake	Entire Reservoir	Laurel

---

# Appendix C

## Locations of Kentucky Wild Rivers

---

Body of Water	Zone	County
<b>Cumberland River Basin</b>		
Bad Branch	Headwaters to KY 932	Letcher
Big South Fork Cumberland River	TN State Line to Blue Heron (Mile 55.2 to Mile 45.0)	McCreary
Cumberland River	Summer Shoals to Lake Cumberland ( Mile 574.6 to Mile 558.5)	McCreary, Whitley
Little South Fork Cumberland River	KY 92 to Lake Cumberland (Mile 14.5 to Mile 4.1)	McCreary, Wayne
Martins Fork	Boundary of Cumberland Gap National Historic Park to KY 987 (Mile 31.3 to Mile 27.4)	Harlan
Rock Creek	TN State Line to White Oak Creek (Mile 21.9 to Mile 3.9)	McCreary
Rockcastle River	KY 1956 at Billows to Lake Cumberland	Rockcastle, Laurel, Pulaski
<b>Green River Basin</b>		
Green River	East boundary of Mammoth Cave National Park to Lock and Dam No. 6 at Brownsville (Mile 207.7 to Mile 181.7)	Edmonson, Hart
<b>Kentucky River Basin</b>		
Red River	KY 746 to Swift Camp Creek (Mile 68.6 to Mile 59.5)	Wolfe, Menifee

# Appendix D

## High-Quality Waters

---

Stream	Zone	County
<b>Little Sandy River Basin</b>		
Arabs Fork*	Source to confluence with Clay Fork	Carter
Big Caney Creek*	Source to Grayson Lake	Elliot
Big Stinking Creek*	Source to River Mile 10.7	Carter
Laurel Creek*	Source to River Mile 7.6	Elliot
<b>Licking River Basin</b>		
Bucket Branch*	Source to confluence with North Fork of the Licking River	Morgan
Devils Fork*	Source to confluence with North Fork of the Licking River	Morgan
North Fork of Licking River*	Source to River Mile 13.0	Morgan
<b>Kentucky River Basin</b>		
Clear Creek*	Source to River Mile 4.1	Woodford
Clemons Fork*	Source to Buckhorn Creek	Breathitt
Coles Fork*	Source to Buckhorn Creek	Breathitt
Right Fork of Buffalo Creek*	Source to Buffalo Creek	Owsley
South Fork of Station Camp Creek*	Source to River Mile 5.3	Jackson
Station Camp Creek*	River Mile 22.3 to 19.0	Estill
Sturgeon Creek*	Source to River Mile 4.0	Lee
<b>Salt River Basin</b>		
Salt Lick Creek*	Source to River Mile 5.3	Marion
Wilson Creek*	Source to River Mile 12.2	Bullitt

## Appendix D *continued*

---

<b>Stream</b>	<b>Zone</b>	<b>County</b>
<b>Green River Basin</b>		
Beaverdam Creek*	Source to River Mile 7.6	Edmonson
Gasper River*	Source to River Mile 32.3	Logan
Goose Creek*	Source to River Mile 5.6	Casey
Green River	River Mile 207.8 to 181.7	Edmonson
Russell Creek*	Source to River Mile 60.5	Adair
Trammel Fork*	River Mile 30.15 (Kentucky/Tennessee State line) to River Mile 19.4	Allen
<b>Lower Cumberland River Basin</b>		
Whippoorwill Creek*	Source to Red River	Logan
<b>Tennessee River Basin</b>		
Blood River*	River Mile 15.65 (KY/TN state line) to 15.1	Calloway
Soldier Creek*	River Mile 5.3 to 2.6	Marshall
<b>Tradewater River Basin</b>		
Sandlick Creek*	Source to River Mile 3.5	Christian
Tradewater River*	Source to River Mile 126.0	Christian
<b>Ohio River Basin</b>		
Yellowbank Creek*	Source to River Mile 4.4	Breckinridge
<b>Lakes and Reservoirs</b>		
Metropolis	Entire Lake	McCracken
Swan	Entire Lake	Ballard
<b>Mississippi River Basin (Main Stem and Minor Tributaries)</b>		
Murphy's Pond	Entire Pond and Preserve Area	Hickman

---

## Appendix D *continued*

<b>Stream</b>	<b>Zone</b>	<b>County</b>
<b>Upper Cumberland River Basin</b>		
Bad Branch*	Source to confluence with Poor Fork of Cumberland River	Letcher
Bark Camp Creek*	Source to River Mile 2.6	Whitley
Buck Creek*	River Mile 62.6 to 28.9	Pulaski
Cane Creek*	Source to River Mile 7.0	Laurel
Cumberland River	River Mile 574.6 to 558.5 (Headwaters of Lake Cumberland)	McCreary/Whitley
Eagle Creek*	Source to River Mile 3.0	McCreary
Horse Lick Creek*	Source to River Mile 12.3	Jackson
Little South Fork of Cumberland River	River Mile 35.6 to 4.1	Wayne
Marsh Creek*	Source to River Mile 12.6	McCreary
Martins Fork of Cumberland River	River Mile 31.3 to 27.4	Harlan
Rock Creek	TN/KY State Line (River Mile 21.9) to White Oak Creek	McCreary
Rockcastle River	River Mile 24.4 to 8.5	Laurel/Pulaski
South Fork of Dog Slaughter Creek*	Source to Dog Slaughter Creek	Whitley

\* Bodies of water in the Kentucky Cabinet for Natural Resources and Environmental Protection reference reach network

# Appendix E

## Surface Waters Categorized as Outstanding National Resource Waters

---

<b>Stream</b>	<b>Zone</b>	<b>County</b>
Red River	River Mile 68.6 to 49.2	Menifee/Wolfe
Underground River System	Within Mammoth Cave National Park	Edmonson/ Hart/
	Boundary	Barren
Big South Fork of Cumberland River	River Mile 55.2 to 45.0	McCreary

---

# Appendix F

## Technical Assistance Providers: State Offices

---

The application of BMPs in the field requires a certain amount of planning before initiating the forest activity. Considerable information is currently available from state and federal agencies. The following agencies are available for technical assistance in Kentucky and have representatives that operate on a local county level. Industrial and consulting foresters are also available for information and assistance.

Kentucky Division of Forestry  
627 Comanche Trail  
Frankfort, KY 40601  
(502) 564-4496

Natural Resources Conservation Service  
771 Corporate Drive, Suite 110  
Lexington, KY 40503  
(606) 224-7350

Kentucky Department of Fish and Wildlife Resources  
No. 1 Game Farm Road  
Frankfort, KY 40601  
(502) 564-3400

University of Kentucky  
Cooperative Extension Service  
College of Agriculture-Department of Forestry  
T.P. Cooper Bldg.  
Lexington, KY 40546-0073  
(606) 257-7596

Kentucky Division of Water  
14 Reilly Road  
Frankfort, KY 40601  
(502) 564-3410

Kentucky Division of Forestry  
District Offices

**Northeastern District**  
Kentucky Division of Forestry  
749 West First Street  
Morehead, KY 40351  
(606) 784-7504

**Central District**

Kentucky Division of Forestry  
P.O. Box 663  
Elizabethtown, KY 42702  
(502) 766-5010

**Southeastern District**

Kentucky Division of Forestry  
P.O. Box 130  
Pineville, KY 40977  
(606) 337-3011

**South Central District**

Kentucky Division of Forestry  
120 Gaines Drive  
Campbellsville, KY 42718  
(502) 465-5071

**Kentucky River District**

Kentucky Division of Forestry  
P.O. Box 702  
Hazard, KY 41702  
(606) 435-6073

**Green River District**

Kentucky Division of Forestry  
P.O. Box 465  
Madisonville, KY 42431  
(502) 824-7527

**Eastern District**

Kentucky Division of Forestry  
P.O. Box 189  
Betsy Layne, KY 41605  
(606) 478-4495

**Western District**

Kentucky Division of Forestry  
P.O. Box 349  
Mayfield, KY 42066  
(502) 247-3913

**Bluegrass District**

Kentucky Division of Forestry  
P.O. Box 30  
Stamping Ground, KY 40379  
(502) 535-7741



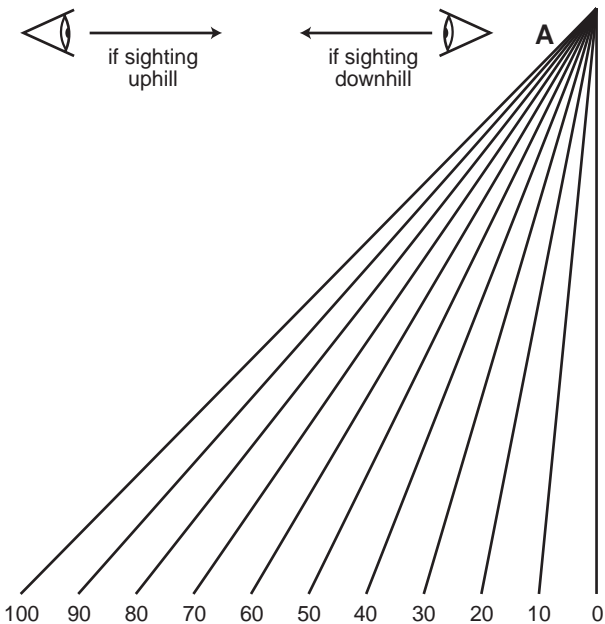

**Use to measure percent slope**

Attach a weighted string to corner **A** and sight using the top edge of the handbook. Sight to a target that is the same height above the ground as your eye level. Read the percent slope where the string crosses the bottom markings.

Educational programs of the Kentucky Cooperative Extension Service serve all people regardless of race, color, age, sex, religion, disability, or national origin. Issued in furtherance of Cooperative Extension work, Acts of May 8 and June 30, 1914, in cooperation with the U.S. Department of Agriculture, C. Oran Little, Director of Cooperative Extension Service, University of Kentucky College of Agriculture, Lexington, and Kentucky State University, Frankfort. Copyright © 1998 for materials developed by the University of Kentucky Cooperative Extension Service. This publication may be reproduced in portions or its entirety for educational or nonprofit purposes only. Permitted users shall give credit to the author(s) and include this copyright notice. Publications are also available on the World Wide Web at: <http://www.ca.uky.edu>. Issued 3-98, 12,000 copies