

KEH-106

# **Kentucky Extension Homemakers**

## **Cultural Arts and Heritage**

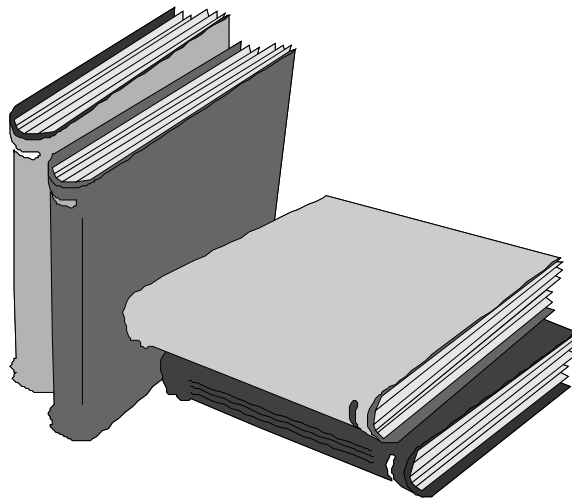

# **BOOK LIST**

## **2009 to 2010**

**Kentucky Extension Homemakers Association**

## BOOK LIST 2009 to 2020

The KEHA Cultural Arts and Heritage program area annually sponsors a reading program. Extension Homemakers may participate by reading one book from six of the ten categories listed: the arts, biography, family and consumer sciences, family life, fiction, history, Kentucky, religion, travel, or children's (preschool, primary, and middle school).

Keep a record of the books you read and submit that record to your local Cultural Arts and Heritage chair. Qualified readers may receive the Cultural Arts Reading Award.

Remember, **this is only a suggested list**. You may choose your own titles. Your local public librarian may have other suggestions. Local libraries usually belong to the Kentucky Library Network which allows individuals to borrow books from other libraries through inter-library loan. If you cannot find the book you wish to read, ask about this service.

### THE ARTS

***Make 'Em Laugh: The Funny Business of America*** by Laurence Masion and Michael Kantor. Twelve Publishing, 2008. ISBN: 0446505315.

The book gives readers an illuminating look at the past century of American comedy and the talents who created it. Learn what makes us laugh and why.

***The Quilts of Gee's Bend: Masterpieces from a Lost Place*** by William Arnett, Alvia Wardlaw, Jane Livingston, and John Beardsley. Tinwood Books, 2002. ISBN: 0965376648.

Gee's Bend is an isolated area of Alabama where the women have created beautiful handmade quilts from whatever materials were available, in patterns of their own imaginative design. This book includes information on the quilters and full-page photographs.

***How to Market and Sell Your Art, Music, Photographs, & Handmade Crafts Online: Turn Your Hobby into a Cash Machine*** by Lee Rowley. Atlantic Publishing Company, 2008. ISBN: 1601381468.

Learn the steps to successfully sell your artwork or crafts online. This book will help you develop a marketing plan using practical ideas.

## BIOGRAPHY

***A Passion for Nature: The Life of John Muir*** by Donald Worster. Oxford University Press, 2008. ISBN: 0195166825.

John Muir is revered as the founder of the modern American conservation movement. Based on Muir's private correspondence, this biography explores the complex inner life behind the legend of this solitary mountain man.

***Too Close to the Sun: Growing Up in the Shadow of My Grandparents, Franklin and Eleanor*** by Curtis Roosevelt. PublicAffairs, 2008. ISBN: 1586485547.

Franklin D. Roosevelt's grandson describes his strange and wondrous coming-of-age in the White House—and the perils of a public childhood.

***Madeline McDowell Breckinridge and the Battle for the New South*** by Melba Porter Hay. University Press of Kentucky, 2009. ISBN: 9780813125329.

This Kentucky native was at the forefront of the suffrage movement at both the state and national level. She was the great-granddaughter of Henry Clay and a descendant of several Bluegrass families. This is an account of the hardships that changed her into a selfless advocate for the disadvantaged. Among her many causes were social programs for the poor, compulsory school attendance, laws regulating child labor voting rights, and the antituberculosis movement.

## FAMILY AND CONSUMER SCIENCES

### Clothing and Textiles

***The Kitchen Linens Book: Using, Sharing, and Cherishing the Fabrics of Our Daily Lives*** by EllynAnne Geisel. Andrews McMeel Publishing, 2009. ISBN: 0740777637.

This book is a five-star winner. It gives us an up-close look at tablecloths, dishtowels, and napkins with details and histories. Each is a memory of our mothers and grandmothers. Includes 20 projects and 8 recipes.

## Family Resource Management

***Your Credit Score: How to Fix, Improve, and Protect the 3-Digit Number that Controls Your Financial Future*** by Liz Pulliam Weston. FT Press, 2007. ISBN: 0132254581.

This book offers good, solid, easy-to-understand advice on how to improve your credit score. Learn how to cope with a credit crisis and how to bounce back from bad credit or bankruptcy; makes complex information, easy to understand.

## Foods and Nutrition

***An Apple a Day: The Myths, Misconceptions, and Truths about the Foods We Eat*** by Joseph A. Schwarcz. Other Press, 2009. ISBN: 1590513118.

Dr. Schwarcz takes his thorough knowledge of food chemistry, and applies it to today's top food fears, trends, and questions. The result is a lighthearted exploration of the misconceptions surrounding the obsession with diets and nutrition.

***1001 Foods You Must Taste Before You Die*** by Frances Case. Universe Publishing, 2008. ISBN: 0789315920.

This book presents a cornucopia of culinary delights from every cuisine around the world — from single press extra-virgin olive oils to zebra jerky.

***What the World Eats*** by Faith D'Aluisio and Peter Menzel. Tricycle Press, 2008. ISBN: 1582462461.

Author and cultural geographer D'Aluisio visited 25 families in 21 countries to create this fascinating look at what people around the world eat in a week.

## Health and Well Being

***Traffic: Why We Drive the Way We Do (and What It Says About Us.)*** by Tom Vanderbilt. Knopf Publishing Group, 2008. ISBN: 0307264785.

Based on exhaustive research and interviews with driving experts, this book is about more than the everyday activity of driving — it's about human nature.

***Snoop: What Your Stuff Says About You*** by Sam Gosling. Basic Books, 2008. ISBN: 0465027814.

For the last 10 years, psychologist Gosling has been studying how people project and protect their inner selves. Now he looks at what can be learned about people simply from looking at their stuff. What he has discovered is astonishing.

## **Home Furnishings**

***The New Terrarium: Creating Beautiful Displays for Plants and Nature*** by Tovah Martin and Kindra Clineff. Clarkson Potter Publishers, 2009. ISBN: 0307407314.

Learn about gardens under glass — the perfect way to spark creativity while incorporating favorite plants in a home.

## **Human Development and Family Relations**

***The Everything Parent's Guide to Raising Your Adopted Child*** by Corrie Lynne Player, Brette McWhorter Sember, and Mary C. Owen. Adams Media, 2008. ISBN: 1598696068.

The author has extensive personal experience with foster children and adoption. Chapter topics include adopting as: a grandparent, older siblings, stepparents, single parent, older parents, and same-sex couples. Other topics include adopting outside your ethnic group, international adoptions, adoption through the foster care system, and adopting children of varying ages. The author writes in a clear, conversational style.

***A Parent's Guide to Developmental Delays: Recognizing and Coping with Missed Milestones in Speech, Movement, Learning, and Other Areas*** by Laurie F. LaComer. Perigee, 2006. ISBN: 0399532315.

The author is an expert on developmental and behavioral issues. She supports including children with special needs in regular programs and classes. This book helps identify at an early stage of life what developmental differences look like, and advises trusting your instincts and seeking help if in doubt about whether a child is developing normally.

***The Sensory-Sensitive Child: Practical Solutions for Out-of-Bounds Behavior*** by Karen A. Smith and Daren R. Gouze. Collins Living, 2005. ISBN: 0060527188.

The authors first tell their own stories of struggles to understand and cope with their children's misbehavior. When they discovered the sensory processing problems at the root of the behavior and changed their parenting methods, their children responded like different people. The book shows how to recognize sensory-processing difficulties, evaluate treatment options, and gain strategies for handling the challenges.

## FAMILY LIFE

***The Soul of a Horse: Life Lessons from the Herd*** by Joe Camp. Harmony, 2008. ISBN: 0307406857.

This is an emotional, humorous, story of Joe and his wife, as they plunge into the work of horses. The lessons of this book apply not just to horses, but to life and to all of us. "Who should read this book — every person who has a relationship with a horse, other animals, spouse, family, or other humans — so that includes just about everybody." —*The Rider Magazine*

***Pawprints of Katrina: Pets Saved and Lessons Learned*** by Cathy Scott. Howell Books, 2008. ISBN: 0470228512.

This book includes nearly 200 heroic rescues, heartwarming reunions, and stories of selfless efforts of strangers brought together by a disaster in an effort to save animals at the Best Friends Animal Society.

***The Last Lecture*** by Randy Pausch. Hyperion Press, 2008. ISBN: 1401323251.

The story of a professor at Carnegie Mellon University who is diagnosed with pancreatic cancer. The book is inspiring and often entertaining as it offers life lessons and morals for his young children to learn once he is gone.

***Can We Have One? A Parent's Guide to Raising Kids with Cats and Dogs*** by Lynn F. Buzhardt and Sue D. Steib. Louisiana State University Press, 2008. ISBN: 0807133779.

This convenient, entertaining guide offers a wealth of helpful information for parents considering pet ownership, or pet owners considering parenthood.

## FICTION

***Family Acts*** by Louise Shaffer. Ballantine Books, 2007.  
ISBN: 140006063X.

The story of two women who jointly inherit a mysterious property in Georgia – a rundown theater called the Venable Opera House. They soon learn the history of the theater and the stories of the strong, desperate women who lied, cheated and even killed to keep it in the family. A charming and engaging read.

***The Thirteenth Tale*** by Diane Setterfield. Washington Square Press, 2007. ISBN: 0743298039.

About an author who wrote a book called the 13 tales that only contains 12. Her story, her biographer and the 13<sup>th</sup> tale. Will remind you of Bronte.

***The Guernsey Literary and Potato Peel Pie Society*** by Mary Ann Shaffer and Annie Barrows. Dial Press Trade Paperback, 2009. ISBN: 0385341008.

This book affirms the power of books to nourish people during hard times. It explores the darker side of human nature with lighthearted tone and characterizations.

***The Post-Birthday World*** by Lionel Shriver. Harper Perennial, 2008.  
ISBN: 006118795.

A look at the lusty love choices of Irina, a children's book illustrator living in London. The book unfolds along two tracks: if she stays with her live-in love or if she leaves him for another.

***The Quilter's Apprentice*** by Jennifer Chiaverini. Simon & Schuster, 2008.  
ISBN: 1416556990.

A master quilter in her 70s agrees to teach a young 30 something, out-of-work newcomer to the area how to quilt. During these quilting sessions a family history of wealth and privilege ruined by tragedy unfolds.

## HISTORY

(In celebration of the 200<sup>th</sup> anniversary of Abraham Lincoln's birth, all books in the history section of this list are related to Lincoln.)

***Lincoln Legends: Myths, Hoaxes, and Confabulations associated with Our Greatest President*** by Edward Steer. University Press of Kentucky, 2009. ISBN: 9780813192413.

Some of the most notorious tales and distorted ideas about Lincoln are carefully examined. Steer looks at the evidence and points to the conclusion. Fourteen popular legends are examined. A captivating and informative book.

***Mrs. Lincoln: A Life*** by Catherine Clinton. HarperCollins, 2009. ISBN: 0060760400.

In this remarkable book, Catherine Clinton displays an emotional depth in her understanding of Mary Lincoln that has rarely been revealed in the Lincoln literature.

***The Lincolns: A Scrapbook Look at Abraham and Mary*** by Candace Fleming. Schwartz & Wade Books, 2008. ISBN: 0375836187.

The award-winning author of "Ben Franklin's Almanac" and "Our Eleanor" has created an enthralling joint biography of one of the nation's greatest presidents and his complex wife unlike any other. A scrapbook history that uses photographs, letters, engravings, and even cartoons to form an enthralling museum on the page.

***Manhunt: The Twelve Day Chase for Lincoln's Killer*** by James L. Swanson. William Morrow & Co, Inc., 2006. ISBN: 0060518502.

The murder of Abraham Lincoln set off the greatest manhunt in American history - the pursuit and capture of John Wilkes Booth. From April 14 to 26, 1865, the assassin led Union cavalry and detectives on a wild, twelve-day chase through the streets of Washington, D.C., across the swamps of Maryland, and into the forests of Virginia, while the nation, still reeling from the just-ended Civil War, watched in horror and sadness.

***A. Lincoln: A Biography*** by Ronald C. White, Jr. Random House, 2009. ISBN: 1400064996.

This extensive look at Lincoln shows him as an experienced politician, as he matured and then guided the nation through the four worst years of its history. Includes illustrations, maps, and photos.

***The Assassin's Accomplice: Mary Surratt and the Plot to Kill Abraham Lincoln*** by Kate Clifford Larson. Basic Books, 2008. ISBN: 0465038158.

Looks at the evidence that sent Mary Surratt to her death as an accomplice in Lincoln's assassination. This book captures the atmosphere of her trial and her execution.

***The Lincolns/Portrait of a Marriage*** by Daniel Mark Epstein. Ballantine Books, 2009. ISBN: 0345478002.

This work looks at the marriage of Mary and Abraham and puts aside the stereotypes associated with the Lincolns — that she was mad and he was a saint.

***Team of Rivals: The Political Genius of Abraham Lincoln*** by Doris Kearns Goodwin. Simon & Schuster, 2005. ISBN: 0684824906.

This account of Lincoln offers fresh insight into his leadership style and his deep understanding of human behavior and motivation. His relationship with three rivals for the presidency and how he incorporated them into his cabinet is examined as he gained their support and their admiration.

***Abraham Lincoln: A Life*** by Thomas Keneally. Penguin, 2008. ISBN: 0143114751.

This outstanding biography follows Lincoln from his impoverished birth through his education and presidency.

***Douglas and Lincoln: How a Revolutionary Black Leader and a Reluctant Liberator Struggled to End Slavery and Save the Union*** by Paul Kendrick and Stephen Kendrick. Walker & Company, 2008. ISBN: 0802716857.

This is a study of Lincoln and Douglas and their relationship and evolving rhetoric and how this helped influence Lincoln's view of emancipation, black service in the Union army, and black suffrage.

## KENTUCKY

***Live Like Larry*** by Denny Trease. Wind Publications, 2008.  
ISBN: 9781893239852.

Larry Turner was a role model, for his family, his church, and for many of us in the Kentucky Cooperative Extension Service. This is the story of a man who triumphed over many personal hardships, while working selflessly to inspire others. While he perished in the crash of Comair flight 5191 in September, 2006, his strength and vision continues to inspire all who knew him.

***Kentucky's Best: Fifty Years of Great Recipes*** by Linda Allison-Lewis. University Press of Kentucky, 2009. ISBN: 0813192153.

Recipes in this book combine the traditional dishes of Kentucky homes with the gourmet creations of Kentucky restaurants and inns. Look for classics such as the hot brown, Benedictine spread, or the mint julep.

***Kentucky Cooks: Favorite Recipes from Kentucky Living*** by Linda Allison-Lewis. University Press of Kentucky, 2009. ISBN: 9780813125374.

*Kentucky Living*, the magazine of the Kentucky Association of Electric Cooperatives has the widest circulation of any publication in the state, reaching 487,000 homes and businesses each month. This book is a diverse collection of recipes from 10 years of her popular column in *Kentucky Living*.

***Uneven Ground: Appalachia Since 1945*** by Ronald D. Eller. University Press of Kentucky, 2008. ISBN: 9780813125237.

A passionate, clear, concise and profound representation of observation, experience and research in Appalachia. A revealing insightful look at this region and the politics of economic development.

***Tales from Kentucky Doctors*** by William Lynwood Montell. University Press of Kentucky, 2008. ISBN: 9780813124827.

A fascinating collection of memoirs from Kentucky's medical providers. The stories are both humorous and heartwarming and often tragic. A combination of personal experiences, humorous anecdotes, and local legends.

***Something's Rising: Appalachians Fighting Mountaintop Removal*** by Silas House and Jason Howard. University Press of Kentucky, 2009. ISBN: 9780813125466.

This book serves as a primer on mountaintop removal while it humanizes the practice through the voices and stories of those involved. It is a revealing look at the poverty and exploitation of both the people and the land.

***This is Home Now: Kentucky's Holocaust Survivors Speak*** by Arwen Donahue. University Press of Kentucky, 2009. ISBN: 9780813125473.

After World War II many Jewish Holocaust survivors came to the United States to settle in large metropolitan areas. But some came to rural areas, including Kentucky. Currently about 40 survivors still live in Kentucky. This book focuses on nine of them. Learn their reasons for coming to Kentucky, their reaction to American culture and their stories of integrating into rural American life.

## RELIGION

(Participants Choice)

## TRAVEL

***Novel Destinations: Literary Landmarks from Jane Austen's Bath to Ernest Hemingway's Key West*** by Shannon Schmidt and Joni Rendon. National Geographic Society, ISBN: 142620454X.

Called, the "ultimate browser's delight," this book offers a whirlwind tour of 500 literary landmarks, great reading suggestions, and little-known tales of literary gossip.

***The Complete Guide to Kentucky State Parks*** by Susan Reigler. University Press of Kentucky, 2009. ISBN: 9780813192086.

Much of the beauty and natural environments of Kentucky are preserved in its state parks. The system of 52 state parks is ranked among the nation's finest. This book blends captivating history and breathtaking photos of every park. It offers a firsthand guide for planning a "stay-at-home" vacation this year.

**CHILDREN'S (PRESCHOOL, PRIMARY, MIDDLE SCHOOL)**  
**For suggestions about books for these age groups, contact the**  
**librarian at your local school or public library.**

Thank you to the following for their contributions to this list:

Marjorie M. Baker, Extension Associate for Clothing and Textiles  
Robert H. Flashman, Extension Specialist for Family Resource  
Management  
Carole A. Gnatuk, Extension Specialist for Child Development  
Amy Hoiser, Extension Specialist for Family Life  
Kim Henken, Assistant to the Director  
Patti Burnside, Adult Services Librarian, Scott County Public  
Library

Connee Wheeler, Extension Associate, University of Kentucky Cooperative  
Extension Service

May 2009